

**marelli**

Living  
Collection  
**2016**



# Indice

## *Index*

|          |     |
|----------|-----|
| Clip     | 13  |
| Frame    | 25  |
| Gordon   | 45  |
| Leaf     | 69  |
| Loft     | 77  |
| Matheus  | 97  |
| Mike     | 117 |
| New York | 129 |
| Nicole   | 149 |
| Ribot    | 157 |
| Stone    | 165 |
| Tab      | 173 |
| Twins    | 181 |

# Condizioni generali di vendita

## General sales conditions

### CONDIZIONI GENERALI DI VENDITA

**1** - I prezzi del presente listino si intendono in euro, IVA esclusa.

**2** - La merce, salvo diversamente concordato con la Giulio Marelli Italia S.p.a., si intende resa franco magazzino dell'ordinante, ad eccezione di zone disagiate e isole. Eventuali consegne a indirizzi privati possono essere fatte solo se preventivamente concordate con la Giulio Marelli Italia S.p.a. Anche in questi casi la resa della merce è a piano stradale, senza installazione e la strada deve essere accessibile a grandi camion internazionali. Il sovrapprezzo per questo tipo di consegna deve essere concordato singolarmente di caso in caso.

**3** - Spetta al destinatario il conteggio dei colli e la verifica dello stato di imballaggio prima del ritiro; in caso di mancanza di colli o di danni esterni deve essere fatta immediata riserva sul documento di trasporto dello spedizioniere, ed informare tempestivamente la Giulio Marelli Italia S.p.a.

**4** - La merce si intende franco magazzino per un importo minimo di 500 euro. Per valori inferiori verrà calcolato un contributo per costi di trasporto ed amministrazione di 40 euro.

**5** - La restituzione o lo scambio della merce verranno accettati solo se espressamente autorizzati dalla Giulio Marelli Italia S.p.a.

**6** - Le lavorazioni su misura sono possibili, se indicato nel listino di ogni modello, previo preventivo.

**7** - La Giulio Marelli Italia S.p.a. si riserva di apportare in qualsiasi momento e senza preavviso tutte le modifiche che riterrà opportune per migliorare le qualità tecniche ed estetiche dei propri prodotti.

**8** - Ogni rivestimento in tessuto costa il 50% del prodotto finito.

**9** - La pelle viene venduta con un quantitativo minimo di 2,5 m<sup>2</sup> e, salvo diversamente concordato, non viene venduta tagliata secondo i disegni del cliente.

**10** - Il cliente che desidera ricevere la gomma ignifuga dovrà preciarlo chiaramente nell'ordine, indicando anche gli standard richiesti.

**11** - I colori dei campionari tessuti, finte pelli e pelli, e le finiture del legno si intendono indicativi. Confermando l'ordine il committente accetta eventuali tolleranze di colore.

**12** - I metri cubi e i pesi lordi e netti indicati nel listino si intendono approssimativi, e non vincolano l'azienda ad alcuna responsabilità.

**13** - Non costituiscono elemento di reclamo differenze tra prodotti acquistati in tempi diversi. Se il cliente deve abbinare dei prodotti ad altri prodotti acquistati precedentemente, deve dichiararlo esplicitamente nell'ordine.

**14** - Il presente listino annulla e sostituisce tutti i precedenti.

**15** - Come ufficio giudiziario competente per ogni controversia è competente la sede di Monza (MB).

### GENERAL SALES CONDITIONS

**1** - The prices in this price list are expressed in euro, VAT not included.

**2** - Goods, if not agreed differently with Giulio Marelli Italia S.p.a., are to be considered franco customer's warehouse, with the exception of areas difficult of access and islands.

Deliveries to private addresses can be made only if agreed in advance with Giulio Marelli Italia S.p.a. Also in these cases the goods are delivered at ground floor, without installation, and the road must be accessible to big international trucks. The price increase for this kind of delivery must be agreed on a case-by-case basis.

**3** - The customer has to count the packages immediately and check the condition of the packaging before accepting the goods; in case of lack of packages or presence of exterior damages the customer has to make an immediate reservation on the transport documents of the forwarder and inform promptly Giulio Marelli Italia S.p.a.

**4** - Goods are to be considered franco customer's warehouse for a minimum net amount of 500 euro. For smaller amounts, there will be a contribution to transport and administration costs of 40 euro.

**5** - Goods' return or exchange will be accepted only if expressly authorized by Giulio Marelli Italia S.p.a.

**6** - Special sizes are possible if indicated on the pricelist of each model. Price on request.

**7** - Giulio Marelli Italia S.p.a. reserves the right to make all the necessary modifications to improve the technical and aesthetic quality of the models in any time and without prior notice.

**8** - Any further cover in fabric costs 50% of the final product.

**9** - Leather is sold in a minimum quantity of 2,5 m<sup>2</sup>. If not agreed differently, it is not sold according to customer's drawings.

**10** - Customers who wish to receive fire retardant foam have to specify it clearly in the order, and also have to indicate the required standards.

**11** - Colours of fabric, leatherlook and leather samples and wood finishings are only indicative. By confirming the order the customer accepts any possible small differences.

**12** - Cubic meters, gross and net weights in the price list are approximate and don't bind the company to any responsibility.

**13** - Differences between products bought in different times are not element of complaints. If the customer has to combine products to others bought previously, he should clearly express this in the order.

**14** - This price list cancels and replaces all the previous ones.

**15** - The competent court for any controversy is Monza (MB).

### CONDITIONS GENERALES DE VENTE

**1** - Les prix figurant dans ce tarif sont en euro et hors taxe.

**2** - La marchandise, sauf autrement établi avec Giulio Marelli Italia S.p.a., s'entend franco de port au dépôt du client, à l'exception des zones difficiles à atteindre et des îles.

Livraisons aux adresses particulières peuvent être effectuées seulement si concordées par avance avec Giulio Marelli Italia S.p.a. Aussi dans ces cas la marchandise est livrée au rez-de chaussée, sans installation, et la rue doit être accessible aux grands camions internationaux. Le supplément de prix pour ce genre de livraison doit être concordé individuellement pour chaque cas.

**3** - Le client doit compter les colis immédiatement et vérifier l'état de l'emballage avant le retrait; dans le cas d'absence de colis ou dommage extérieur le client doit faire immédiatement réserve sur le document de transport du transporteur et informer en temps utile Giulio Marelli Italia S.p.a.

**4** - La marchandise s'entend franco votre dépôt pour un montant minimum de 500 euros net.

Pour montants de commande inférieurs, une participation forfaitaire de 40 euros pour coûts de transport et administration sera appliquée.

**5** - La restitution ou l'échange de marchandise ne sera acceptée qu'après avis favorable par Giulio Marelli Italia S.p.a.

**6** - Sur mesure est possible pour chaque modèle où c'est indiqué dans le tarif. Prix sur demande.

**7** - Giulio Marelli Italia S.p.a. se réserve le droit d'apporter, en tout moment et sans aucun avis préalable, toutes les modifications qu'elle croira nécessaires, afin d'améliorer la qualité technique et esthétique de ses produits.

**8** - Chaque revêtement en tissu coûte 50% du produit fini.

**9** - Le cuir est vendu par quantité minimum de 2,5 m<sup>2</sup> et, sauf accords différents, n'est pas vendu selon les dessins du client.

**10** - Le client qui désire recevoir la mousse ignifuge devra le préciser clairement sur la commande, en indiquant aussi les normes.

**11** - Les couleurs des collections d'échantillons de tissu, cuir look et cuir et finitions du bois sont indicatives. Avec la confirmation de la commande, le client accepte de petites différences de couleur éventuelles.

**12** - Les mètres cubes et les poids bruts et nets dans le tarif s'entendent approximatifs et il s'en tient à maison à aucune responsabilité.

**13** - Différences entre produits achetés en temps différents ne constituent élément de réclamation. Si le client doit combiner des produits à d'autres achetés précédemment, il doit l'indiquer explicitement dans la commande.

**14** - Ce tarif annule et remplace tous les précédents.

**15** - Tribunal compétent pour chaque litige est celui de Monza (MB).

### ALLGEMEINE VERKAUFSBEDINGUNGEN

**1** - Die Preise der vorliegenden Verkaufspreisliste sind in Euro berechnet.

**2** - Die Ware, wenn nicht anders mit Giulio Marelli Italia S.p.a. vereinbart, versteht sich frei Kundenlager, mit Ausnahme von schwer erreichbaren Gegenden und Inseln. Eventuelle Lieferungen an Privatadressen sind möglich, nur wenn sie vorab mit Giulio Marelli Italia S.p.a. vereinbart werden. Auch in diesen Fällen wird die Ware am Erdgeschoss ohne Installation geliefert, und die Strasse muss grossen internationalen Lkws zugänglich sein. Der Mehrpreis für diese Art von Lieferungen muss individuell für jeden einzelnen Fall vereinbart werden.

**3** - Der Kunde muss die angelieferten Frachtstücke zählen, den Zustand der Verpackung vor Annahme überprüfen; im Fall von Mängeln an Frachtstücken oder äusseren Schäden muss der Kunde unverzüglich Vorbehalte auf die Dokumente des Transporteurs äussern und rechtzeitig Giulio Marelli Italia S.p.a. darüber informieren.

**4** - Die Ware wird ab einem Netto-Einkaufswert von 500 Euro frei Haus geliefert. Für Lieferungen darunter berechnen wir einen Frachtanteil an Transport- und Verwaltungskosten von 40 Euro.

**5** - Rücknahme oder Austausch von Waren können nur nach vorheriger Genehmigung durch Giulio Marelli Italia S.p.a. vorgenommen werden.

**6** - Sonderanfertigungen sind möglich, wenn es auf der Preisliste des Modells angegeben ist. Preis auf Anfrage.

**7** - Giulio Marelli Italia S.p.a. behält sich das Recht vor, jederzeit und ohne Vorankündigung alle zur Verbesserung der technischen und ästhetischen Qualitäten für nötig gehaltenen Veränderungen an ihren Produkten anzubringen.

**8** - Genähte Komplettbezüge (Hüllen) in Stoff können zum Preis von 50% des beendeten Produkts geliefert werden.

**9** - Leder kann nur in einer Mindestmenge von 2,5 Quadratmetern geliefert werden. Zuschnitt des Leders nach Kundenzeichnung ist nicht möglich, wenn nicht anders vereinbart.

**10** - Kunden, die feuerhemmenden Schaum erhalten möchten, sollen es auf dem Auftrag zusammen mit den benötigten Standards spezifizieren.

**11** - Die Farben der Stoff-, Kunstleder-, Lederund Holzmuster sind ungefähr. Durch die Auftragbestätigung nimmt der Kunde mögliche kleine Farbverschiedenheiten an.

**12** - Die Kubikmeter, die Brutto- und Nettogewichte in der Preisliste sind annähernd und sie binden die Firma zu keinen Verantwortungen.

**13** - Verschiedenheiten zwischen in verschiedenen Zeiten gekaufte Produkte stellen keine Elemente von Reklamation dar. Wenn der Kunde Produkte mit anderen vorherig gekauften Produkten koppeln muss, muss er das klar auf dem Auftrag erklären.

**14** - Die vorliegende Preisliste annulliert und ersetzt alle Vorgehenden.

**15** - Zuständiges Gericht für jeden Streit ist Monza (MB).

### ALGEMENE VERKOOPSVOORWAARDEN

**1** - De prijzen in onderhavige prijslijst zijn in euro exclusief btw.

**2** - Tenzij anders overeengekomen met Giulio Marelli Italia S.p.a., worden de goederen franco magazijn van de opdrachtgever geleverd, met uitzondering van moeilijk bereikbare plaatsen en eilanden. Eventuele leveringen bij particulieren zijn enkel mogelijk als ze van tevoren zijn afgesproken met Giulio Marelli Italia S.p.a. Ook in deze gevallen worden de goederen gelijkvloers geleverd, zonder inhuizing en de straat dient toegankelijk te zijn voor grote internationale vrachtwagens. De meerprijs voor dit soort levering dient geval per geval van tevoren overeengekomen te worden.

**3** - De opdrachtgever dient de colli's onmiddellijk te tellen en de staat van de verpakking voor het uitpakken te controleren. In geval van ontbrekende colli's of externe beschadigingen dient de opdrachtgever dit onmiddellijk aan te duiden op het vervoerdocument van de transporteur en Giulio Marelli Italia S.p.a. zo spoedig mogelijk schriftelijk op de hoogte te brengen.

**4** - De goederen worden franco magazijn geleverd vanaf een aankoopbedrag van 500 euro netto. Bij een lager aankoopbedrag zal een deelname van 40 euro in de transport- en administratiekosten aangerekend worden.

**5** - Teruggave of omruiling van goederen wordt slechts aanvaard na uitdrukkelijke goedkeuring door Giulio Marelli Italia S.p.a.

**6** - Maatwerk is mogelijk bij elk model waar dit in de prijslijst aangegeven is. Prijs op aanvraag.

**7** - Giulio Marelli Italia S.p.a. behoudt zich het recht voor op elk moment en zonder voorafgaandelijk bericht alle wijzigingen aan te brengen die het nodig acht om de technische en esthetische kwaliteit van zijn producten te verbeteren.

**8** - Elke extra bekleding in stof kost 50% van het afgewerkte product.

**9** - Leder wordt verkocht vanaf een minimum van 2,5 m<sup>2</sup> en wordt, tenzij anders overeengekomen, niet volgens tekening van de klant versneden.

**10** - Wanneer een klant brandvertragend koudschuim wenst, dient hij dit duidelijk aan te geven in zijn bestelling, met vermelding van de gewenste norm.

**11** - De kleuren van de stof-, lederlook-, leder- en houtstalen zijn louter indicatief. Door het order te plaatsen, aanvaardt de opdrachtgever eventuele kleurverschillen.

**12** - De kubieke meters en de bruto- en nettogewichten vermeld in de prijslijst zijn benaderend en impliceren geen enkele verantwoordelijkheid van Giulio Marelli Italia S.p.a.

**13** - Verschillen tussen producten aangekocht op verschillende tijdstippen vormen geen aanleiding tot klachten. Wanneer de klant producten dient te combineren met reeds vroeger aangekochte producten, dient hij dit duidelijk aan te geven in zijn bestelling.

**14** - De huidige prijslijst vervangt en vernietigt alle voorgaande.

**15** - Voor elk geschil is de rechtbank van Monza (MB) bevoegd.

# Consigli per la vendita

## *Sales advice*

### CONSIGLI PER LA VENDITA

**1** - Il divano è un prodotto che ha una sua vita e il suo aspetto cambia in base all'utilizzo che ne viene fatto. L'utilizzo del divano implica una deformazione dei cuscini, deformazione decisamente più contenuta nel caso di cuscini in gomma e più accentuata nei cuscini in piuma, soprattutto se non vengono osservate le indicazioni per la manutenzione della piuma presenti sul nostro catalogo. A chi non desiderasse un divano dall'aspetto più "vissuto" raccomandiamo la scelta di cuscini in gomma. Informiamo infatti i gentili clienti che non verranno più effettuate sostituzioni di cuscini in piuma con cuscini in gomma a titolo gratuito. I cuscini in piuma già utilizzati verranno d'ora in poi sostituiti solo con addebito.

**2** - I tessuti di ciniglia vengono spesso scelti per la loro piacevole caratteristica di morbidezza, conferita al tessuto dalla presenza del pelo della ciniglia, che con l'utilizzo tende a schiacciarsi e creare delle zone in cui questa caratteristica è maggiormente evidente, rendendo l'aspetto del divano più "vissuto". Per ravvivare il pelo schiacciato della ciniglia si può vaporizzare l'area in cui il pelo è schiacciato o procedere con un lavaggio a secco del tessuto. Se il cliente non desiderasse agire in questo modo, raccomandiamo vivamente la preferenza di tessuti dall'aspetto più uniforme.

**3** - Nel corso dei mesi e degli anni, la Giulio Marelli si riserva il diritto e il dovere di apportare delle seppur minime modifiche ai modelli per migliorare la costruzione e i materiali utilizzati. Divani, poltroncine o tavolini acquistati in un secondo tempo per accompagnare merce precedente, non potranno mai essere completamente identici. Ciò vale anche per i tessuti e le pelli utilizzati per i rivestimenti che, appartenendo a lotti di produzione diversi, presentano delle piccole differenze tollerate per legge.

**4** - Il marmo è un materiale naturale, poroso, delicato e che non è mai uniforme. Chi desiderasse aumentarne la resistenza deve ordinare il tavolino con top in marmo espressamente con trattamento poliestere lucido antimacchia, in grado di proteggere maggiormente la superficie marmorea.

**5** - Anche la finitura satinata del vetro retro verniciato è delicata. Coloro che la ordinano espressamente devono esserne consapevoli per evitare problemi futuri.

### SALES ADVICE

**1** - The sofa has its own life and the sofa look changes according to the use you make of it. The use of the sofa causes a change in the shape of the cushions; this is not so evident in case of foam cushions and much more marked in case of feather cushions, especially if you do not follow the feather maintenance instructions expressed in our catalogue. We recommend to choose foam cushions to those who do not wish to have a sofa with a more "used look". We inform our clients that we will no longer substitute feather cushions with foam cushions for free. Substitutions of used feather cushions will be charged.

**2** - Chenille fabrics are often chosen for their pleasant soft touch, which is typical for chenille fabrics due to the presence of the pile. The chenille pile tends to become flat with use and to create areas where this characteristic is more marked, thus making the sofa look more "used". In order to revitalize the chenille pile, you can vaporize the area where the pile has become flat with iron or dry clean the fabric. If the customer does not wish to follow these care instructions, we recommend to choose fabrics with a more uniform look.

**3** - Over the months and the years, Giulio Marelli reserves the right and the duty to make some changes to the models, in order to improve the construction and the materials they are built with. Sofas, armchairs or coffee tables delivered afterwards to accompany previously delivered goods cannot be identical to the previous ones. Also fabrics and leathers will present some small differences tolerated by law, because they belong to different batches.

**4** - Marble is a natural, porous and easily stained material, which is never uniform. To those who wish to increase the marble resistance we recommend to order the coffee table with marble top expressly with polished stain-resistant polyester treatment, which protects the marble surface better.

**5** - Also the satinated finish of the back-painted glass is delicate. Those who order it expressly must be aware of it in order to avoid any problem in the future.

### CONSEILS POUR LA VENTE

**1** - Un canapé ou un fauteuil est un produit qui a sa vie à lui et son aspect change à base de l'utilisation qui en est faite. L'utilisation du canapé ou fauteuil implique une déformation des coussins, déformation plutôt limitée dans le cas de coussins en mousse et plus prononcée dans le cas de coussins en duvet, surtout si les directives en matière d'entretien de coussins en duvet que l'on peut trouver dans notre catalogue ne sont pas respectées. A ceux qui ne souhaitent pas de canapé ou fauteuil à l'aspect «vécu», nous recommandons de choisir des coussins en mousse. Nous vous informons qu'en effet, nous ne remplacerons plus gratuitement des rembourrages en duvet par des rembourrages en mousse. Le remplacement de rembourrages en duvet déjà utilisés devra désormais être payé.

**2** - Les tissus de chenille sont souvent choisis pour leur agréable caractéristique de douceur, que la présence du poil de la chenille donne au tissu. Lors de l'usage, ce poil tend à s'écraser et à créer des zones dans lesquelles cette caractéristique se montre davantage, ce qui donne au canapé ou fauteuil un aspect plus «vécu». Pour faire revivre le poil écrasé de la chenille, on peut nettoyer à la vapeur la zone dans laquelle le poil est écrasé ou passer au nettoyage à sec du tissu. Si le client ne souhaite pas agir de telle manière, nous recommandons vivement de choisir des tissus qui ont un aspect plus uniforme.

**3** - Marelli se réserve le droit, et le considère aussi son devoir, d'appliquer de petites modifications, quelque minimes qu'elles soient, aux modèles au cours des mois et des années afin d'améliorer la construction et les matériaux utilisés. Des canapés, fauteuils ou tables basses achetés dans un second temps pour être assortis à meubles existants ne pourront jamais être complètement identiques. Ceci vaut aussi pour les tissus et les cuirs utilisés pour les revêtements: puisqu'ils viennent de lots différents de production, ceux-ci présentent de petites différences juridiquement acceptées.

**4** - Le marbre est une matière naturelle, poreuse, délicate et qui n'est jamais uniforme. Qui souhaite augmenter la résistance de la tablette en marbre devrait la commander avec un traitement anti-taches en polyester transparent brillant, qui protège mieux la superficie du marbre.

**5** - La finition satinée du verre laqué de dessous est également délicate. Qui la commande, doit bien s'en rendre compte pour éviter de futurs problèmes.

### EMPFEHLUNGEN ZUM VERKAUF

**1** - Das Sofa hat sein eigenes Leben und sein Aussehen ändert sich wegen Benutzung. Die Benutzung des Sofas führt zu einer Verformung der Kissen; dies ist bei Daunenkissen unzweifelhaft viel sichtlicher als bei Schaumkissen, vor allem wenn die Wartungsanleitungen fuer Daunenkissen in unserem Katalog nicht berücksichtigt werden. Kunden, die kein Sofa mit solchem „gebrauchten“ Aussehen haben moechten, empfehlen wir Schaumkissen. Wir moechten unsere Kunden informieren, dass Daunenkissen nicht mehr durch Schaumkissen frei ersetzt werden. Schon benutzte Daunenkissen werden ab sofort nur gegen Berechnung ersetzt werden.

**2** - Chenillestoffe werden oft aufgrund ihres angenehmen weichen Gefühls gewählt. Ihre Weichheit ist auf das Flor der Chenille zurückzuführen, das aber wegen Benutzung flach werden kann. Auf diese Weise können Druckstellen, die sogenannten Sitzspiegel entstehen, aber dabei handelt es sich um eine warentypische Erscheinung, nicht um einen Qualitätsmangel. Um das Flor wieder zu erheben, kann der Stoff gedämpft oder trocken gereinigt werden. Wenn Kunden solche Pflegeanleitungen nicht befolgen moechten, empfehlen wir, Stoffe mit gleichmäßigem Aussehen auszusuchen.

**3** - Im Laufe der Monate und der Jahre behält sich Giulio Marelli das Recht und die Verpflichtung vor, alle zu Verbesserung der Konstruktion und der Materialien der Modelle notwendigen Veränderungen anzubringen. Nachbestellungen können vorigen Bestellungen nicht identisch sein. Das gilt auch fuer Stoffe und Leder, die zu verschiedenen Partien gehören und aus diesem Grund kleine gesetzlich tolerierten Verschiedenheiten aufweisen.

**4** - Marmor ist ein natürliches, delikates, poröses Gestein, das niemals homogen ist. Wenn man die Widerstandsfähigkeit des Marmors erhöhen will, soll der Tisch mit Marmorplatte ausdrücklich fleckabweisend ausgerüstet mittels glänzender Polyesterbehandlung bestellt werden, die die Marmoroberfläche besser schützen kann.

**5** - Auch die satinierte Ausführung des von hinten lackierten Glases ist delikates. Kunden, die diese Ausführung ausdrücklich bestellen, sollen sich davon bewusst sein, um künftige Probleme zu vermeiden.

### TIPS IN VERBAND MET DE VERKOOP

**1** - Een bank of fauteuil is een product dat zijn eigen leven heeft en het uitzicht ervan verandert naargelang het gebruik dat ervan gemaakt wordt. Het gebruik van het product brengt een vervorming van de kussens met zich mee, vervorming die eerder beperkt zal zijn in het geval van kussens met koudschuimvulling en meer uitgesproken in het geval van kussens met donsuvulling, voor ra! als de richtlijnen in verband met het onderhoud van donzen kussens die in onze catalogus te vinden zijn, niet nageleefd worden. Wie geen bank of fauteuil met een "doorleefd" uitzicht wil, raden wij aan voor koudschuimkussens te kiezen. Eventuele vervangingen van dons- door koudschuimvullingen zullen immers niet meer gratis uitgevoerd worden; voor een dergelijke vervanging zal vanaf nu een vergoeding aangerekend worden.

**2** - Chenillestoffen worden vaak gekozen omwille van hun zachte, aangename karakter, dat ontstaat door de pool van de stof, die door het gebruik de neiging heeft plat te gaan liggen en op die manier zones te creëren waarin deze eigenschap des te meer te zien is, waardoor de bank of fauteuil er meer "doorleefd" uitziet. Om de platgedrukte pool van de chenille te doen herleven, kan men de zone waarin de pool platgedrukt is stomen of overgaan tot een chemische reiniging van de stof. Als de klant hiertegen opziet, raden wij ten stelligste aan een stof met een meer gelijkmatig uitzicht uit te kiezen.

**3** - Marelli behoudt zich het recht voor en ziet het ook als zijn plicht om in de loop van de maanden en jaren wijzigingen, hoe gering ook, aan de modellen aan te brengen om de constructie ervan en de gebruikte materialen te verbeteren. Banken, fauteuils, tafeltjes enz. die nadien gekocht worden om bij eerder gekochte producten te passen, zullen nooit exact hetzelfde zijn. Dat geldt ook voor bekledingsmaterialen (stoffen, leders enz.) die, vermits ze uit verschillende productieloten komen, kleine verschillen vertonen die wettelijk aanvaard worden.

**4** - Marmer is een natuurlijk materiaal, poreus, delicaat en nooit gelijk. Wie een tafeltje met marmeren blad bestelt en de duurzaamheid van het blad wil verhogen, kan het tafeltje met een antivlekkenlaag in transparant polyester bestellen, dat het marmeroppervlak beter zal beschermen.

**5** - Ook de matte afwerking van aan de onderkant gelakt glas is delicaat. Wie mat gelakt glas bestelt, dient zich hiervan bewust te zijn om problemen te vermijden.

|  |
|--|
| <b>Tessuti, finte pelli e pelli nella nostra collezione standard (non ignifughi)</b>             |
| <i>Fabrics, artificial leathers and leathers in our standard collection (not fire retardant)</i> |
| <i>Stoffe, Kunstleder und Leder in der Standard-Kollektion (nicht feuerhemmend)</i>              |
| <i>Collection tissus, similicuir et cuirs (non ignifuges)</i>                                    |
| <i>Stof, lederlook- en ledercollectie (niet brandvertragend)</i>                                 |

|                            |                |                 |
|----------------------------|----------------|-----------------|
| <b>Finte pelli</b>         | <b>Tessuti</b> | <b>Pelli</b>    |
| <i>Artificial leathers</i> | <i>Fabrics</i> | <i>Leathers</i> |
| <i>Similicuir</i>          | <i>Stoffe</i>  | <i>Leder</i>    |
| <i>Kunstleder</i>          | <i>Tissus</i>  | <i>Cuir</i>     |
| <i>Lederlook</i>           | <i>Stoffen</i> | <i>Leders</i>   |

|  |  |  |
|--|--|--|
| <b>CAT. B</b><br>A970 (ignifugo / fire retardant / ignifuge /<br>feuerhemmend / brandvertragend) | <b>CAT. C</b><br>12227<br>20240 - 1 - 2<br>14832 - 3 - 4 - 9<br>BILLABONG<br>BRIXTON<br>CLAPMAN<br>ELMAS<br>FELIX<br>LADBROKE<br>METROPOLITAN/METROP/TRIAL/OGIKU<br>PESBA<br>SUN                                     | <b>CAT. SUPER</b><br>DOLLARO<br>PANAMA   |
|  | <b>CAT. D</b><br>ATTRACTIVE<br>BALI<br>LIMBALI<br>RIBES<br>NOBU<br>ROXANNE<br>CRETA 2<br>DUFFY<br>JAZZ<br>PECAN<br>QUIZ<br>T7673<br>F248   | <b>CAT. EXTRA</b><br>BOREA<br>MANHATTAN<br>ELEFANTE<br>NEW JERSEY<br>LORD<br>QUEEN |
|  | <b>CAT. E</b><br>14600<br>ANCUD<br>CALDWELL<br>CAPALBIO<br>COLLISTONE<br>CRESPONE<br>DUNKER<br>INDUSTRY<br>KISHU<br>MECENATE<br>PASUBIO<br>PHONE<br>POVEGLIANO<br>SANTO<br>T7385<br>TORTUGA<br>WHITE<br>F249<br>F250 | <b>CAT. LUSSO</b><br>CIELO<br>STRONG<br>ELITE<br>ACQUARIO<br>NABUK<br>BREVA        |
|  | <b>CAT. F</b><br>INDECENCE<br>LARIO<br>MALAWI/SHILLY<br>PABIS<br>T7623<br>TOKIO  |  |
|  | <b>CAT. G</b><br>DEVOE   |  |

|   |
|---|
| <b>Tessuti, finte pelli e pelli disponibili a richiesta</b>           |
| <i>Fabrics, artificial leathers and leathers available on request</i> |
| <i>Stoffe, Kunstleder, und Leder auf Anfrage verfügbar</i>            |
| <i>Tissus, simili-cuir et cuirs disponibles sur demande</i>           |
| <i>Stoffen, lederlooks en leders leverbaar op aanvraag</i>            |

|                     |                     |                |
|---------------------|---------------------|----------------|
| <b>Produttore</b>   | <b>Produttore</b>   | <b>Tessuto</b> |
| <i>Manufacturer</i> | <i>Manufacturer</i> | <i>Fabric</i>  |
| <i>Lieferant</i>    | <i>Lieferant</i>    | <i>Tissu</i>   |
| <i>Fournisseur</i>  | <i>Fournisseur</i>  | <i>Stoff</i>   |
| <i>Leverancier</i>  | <i>Leverancier</i>  | <i>Stof</i>    |

|   |                      |  |                    |                 |     |
|---|----------------------|--|--------------------|-----------------|-----|
| <b>ALCANTARA</b><br>ALCANTARA RELAX ..... | <b>CAT.</b><br>Extra | <b>KVADRAT</b><br>BLITZ .....              | <b>CAT.</b><br>..G | Cat. B.....     | 63  |
|   |                      | CANVAS .....                               | ..H                | Cat. C.....     | 75  |
| <b>CAMIRA</b><br>BINARY PLUS .....        | ..H                  | CAVA 3 .....                               | ..H                | Cat. D.....     | 93  |
| HEBDEN PLUS .....                         | ..G                  | CODA .....                                 | ..H                | Cat. E.....     | 103 |
| HEIDELBERG .....                          | ..B                  | DIVINA .....                               | ..H                | Cat. F.....     | 114 |
| MANHATTAN .....                           | ..C                  | DIVINA MELANGE .....                       | ..H                | Cat. G.....     | 138 |
| MONROE .....                              | ..G                  | FIELD .....                                | ..G                | Cat. H.....     | 162 |
| SPRINT .....                              | ..C                  | HALLINGDAL .....                           | ..H                |                 |     |
| TIMELINE PLUS .....                       | ..G                  | HOT .....                                  | ..G                |                 |     |
| X2 PLUS .....                             | ..D                  | LAZIO .....                                | ..F                |                 |     |
| BLAZER .....                              | ..E                  | PAUSE .....                                | ..F                |                 |     |
| DENIM PLUS .....                          | ..E                  | PLUS .....                                 | ..H                |                 |     |
| NEW AQUARIUS .....                        | ..E                  | PLUTO .....                                | ..G                |                 |     |
| OXYGEN .....                              | ..F                  | POLO .....                                 | ..G                |                 |     |
| STING PLUS .....                          | ..H                  | REMIX 2 .....                              | ..H                |                 |     |
| XTREME PLUS .....                         | ..B                  | SCUBA .....                                | ..H                |                 |     |
| <b>COTTING</b><br>GINGKO .....            | ..F                  | STEELCUT TRIO 2 .....                      | ..H                |                 |     |
| <b>DE PLOEG</b><br>BERGAMO .....          | ..H                  | SUDDEN .....                               | ..G                |                 |     |
| DUNE .....                                | ..G                  | TONICA .....                               | ..H                |                 |     |
| FEZ .....                                 | ..H                  | TONUS .....                                | ..H                |                 |     |
| HELSINKY .....                            | ..H                  | TOPAS .....                                | ..H                |                 |     |
| KIRUNA .....                              | ..H                  | TUDOR .....                                | ..H                |                 |     |
|   |                      | <b>ONIRO</b><br>NIROXX .....               | ..H                | Cat. Super..... | 139 |
| <b>ENGLISCH DEKOR</b><br>NAPPA .....      | ..D                  | NIROXX LAMÉ .....                          | ..H                | Cat. Extra..... | 202 |
| RHINO II .....                            | ..C                  | NIROXX VELOURS .....                       | ..G                | Cat. Lusso..... | 219 |
| SOFT GRIP .....                           | ..D                  | ULTRAXX .....                              | ..H                |                 |     |
|   |                      | <b>SERGE FERRARI</b><br>STAMSKIN TOP ..... | ..E                |                 |     |
| <b>FANNY ARONSEN</b><br>BALDER II .....   | Extra                | <b>SPRADLING</b><br>VALENCIA .....         | ..E                |                 |     |
| BJÖRG .....                               | Extra                |  |                    |                 |     |
| SNORRE .....                              | Extra                | <b>STOLZ</b><br>CERVO .....                | ..Lusso            |                 |     |
|   |                      | ELEFANTE .....                             | ..Extra            |                 |     |
| <b>GABRIEL</b><br>ATLANTIC .....          | ..B                  | GRAPPA .....                               | ..Extra            |                 |     |
| ARGOS 2 .....                             | ..G                  | SIERRA .....                               | ..Lusso            |                 |     |
| BREEZE .....                              | ..H                  | SELECT .....                               | ..Extra            |                 |     |
| BREEZE FUSION .....                       | ..H                  | SOFTY .....                                | ..Lusso            |                 |     |
| CHESS ROYAL .....                         | ..H                  | <b>VEROTEX</b><br>BONUS .....              | ..H                |                 |     |
| COMFORT .....                             | Extra                | BREEZE .....                               | ..G                |                 |     |
| CRISP .....                               | ..E                  | PALENA .....                               | ..E                |                 |     |
| DELPHI .....                              | ..G                  | PALMA .....                                | ..E                |                 |     |
| DIGITAL 2 .....                           | ..G                  | PAROTEGA NF .....                          | ..F                |                 |     |
| DRAGON .....                              | ..E                  | SOTEGA FLS .....                           | ..F                |                 |     |
| EUROPOST .....                            | ..F                  | SPECTRUM CARE .....                        | ..H                |                 |     |
| EVENT .....                               | ..C                  | TUNDRA .....                               | ..E                |                 |     |
| FAME .....                                | ..D                  | <b>VESCOM</b><br>SANAK .....               | ..F                |                 |     |
| FIGHTER .....                             | ..C                  | KERI .....                                 | ..F                |                 |     |
| GAJA .....                                | ..F                  | DALMA .....                                | ..F                |                 |     |
| GAJA CLASSIC .....                        | ..G                  | BRANDT .....                               | ..F                |                 |     |
| INTERGLOBE WOOL .....                     | ..E                  | DODAN .....                                | ..F                |                 |     |
| LUNA 2 .....                              | ..H                  | LEONE .....                                | ..F                |                 |     |
| LUNA FLEUR 2 .....                        | ..Lusso              | FURKA .....                                | ..F                |                 |     |
| MEDLEY .....                              | ..E                  |  |                    |                 |     |
| STEP/STEP MELANGE .....                   | ..C                  |  |                    |                 |     |
| TEMPT .....                               | ..G                  |  |                    |                 |     |

### I prezzi dei tessuti delle categorie B,C,D,E,F,G,H sono espressi al metro lineare (altezza del tessuto 140 cm.)

*The prices of the fabric categories B,C,D,E,F,G,H are expressed per linear metre (fabric height: 140 cm.)*  
*Les prix des tissus des catégories B,C,D,E,F,G,H sont exprimés au mètre linéaire (hauteur du tissu 140 cm.)*  
*Die Preise der Stoffkategorien B,C,D,E,F,G,H sind per Linearmeter ausgedrückt (Stoffhöhe: 140 cm.)*  
*De prijzen van de stoffen categorie B,C,D,E,F,G,H zijn uitgedrukt in lopende meter (stofbreedte 140 cm)*

|                |
|----------------|
| <b>Pelle</b>   |
| <i>Leather</i> |
| <i>Leder</i>   |
| <i>Cuir</i>    |
| <i>Leder</i>   |

|                 |     |
|-----------------|-----|
| Cat. Super..... | 139 |
| Cat. Extra..... | 202 |
| Cat. Lusso..... | 219 |

### Il prezzo delle pelli è espresso al metro quadro

*The leather price is expressed per square metre*  
*Le prix des cuirs est exprimé au mètre carré*  
*Der Lederpreis ist per Quadratmeter ausgedrückt*  
*De prijs van het leder is uitgedrukt in vierkante meter*

### Contattateci per avere un preventivo di articoli non compresi in questi elenchi









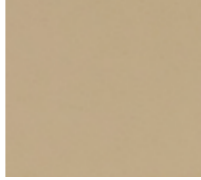

*Please contact us for a quotation for fabrics that are not in this list.*  
*Bitte kontaktieren Sie uns fuer eine Preisangabe fuer Artikel, die nicht in dieser Liste stehen.*  
*Veillez nous contacter pour un devis pour tissus qui ne sont pas dans cette liste.*  
*Gelieve ons te contacteren voor een prijsopgave voor stoffen die niet in deze lijst staan.*

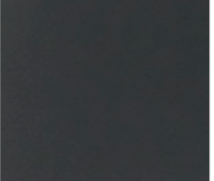
# Colori e finiture

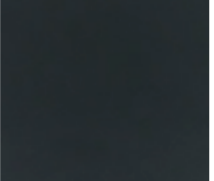
## Colours and finishes











### Metalli

#### Metal

|   |   |  |   |
|---|---|--|---|
| <b>OPM1</b><br>Metallo cromo lucido<br>Shiny chrome metal<br>Metall glänzend verchromt<br>Métal chromé brillant<br>Metaal chroom  |    | <b>OPM10</b><br>Metallo verniciato golden beach<br>Golden beach painted metal<br>Metall golden beach lackiert<br>Métal laqué golden beach<br>Metaal golden beach gelakt              |    |
| <b>OPM2</b><br>Metallo spazzolato cromo satinato<br>Brushed matt chrome metal<br>Metall matt verchromt (gebürstet)<br>Métal chromé mat (brossé)<br>Metaal matchroom (geborsteld)    |    | <b>OPM11</b><br>Metallo verniciato gold pearl<br>Gold pearl painted metal<br>Metall gold pearl lackiert<br>Métal laqué gold pearl<br>Metaal gold pearl gelakt                        |    |
| <b>OPM3</b><br>Metallo spazzolato canna di fucile<br>Brushed matt dark grey metal<br>Metall dunkelgrau gebürstet<br>Métal brossé canon de fusil<br>Metaal geborsteld canon de fusil |   | <b>OPM12</b><br>Metallo spazzolato rame<br>Brushed copper metal<br>Metall Kupfer gebürstet<br>Métal brossé cuivre<br>Metaal geborsteld koper   |   |
| <b>OPM6</b><br>Metallo verniciato RAL 9017 nero<br>RAL 9017 black painted metal<br>Metall RAL 9017 schwarz lackiert<br>Métal laqué noir RAL 9017<br>Metaal RAL 9017 zwart gelakt    |  | <b>OPM13</b><br>Metallo spazzolato ottone antico<br>Brushed antique brass metal<br>Metall Antik Messing gebürstet<br>Métal brossé laiton antique<br>Metaal geborsteld antiek messing |  |
| <b>OPM7</b><br>Metallo verniciato RAL 9016 bianco<br>RAL 9016 white painted metal<br>Metall RAL 9016 weiss lackiert<br>Métal laqué blanc RAL 9016<br>Metaal RAL 9016 wit gelakt     |  | <b>OPM14</b><br>Metallo cromo nero lucido<br>Shiny black chrome metal<br>Metall schwarz glänzend verchromt<br>Métal chromé noir brillant<br>Metaal zwart chroom                      |  |
| <b>OPM9</b><br>Metallo verniciato classic bronze<br>Classic bronze painted metal<br>Metall classic bronze lackiert<br>Métal laqué classic bronze<br>Metaal classic bronze gelakt    |  | <b>OPM15</b><br>Metallo spazzolato oro antico<br>Brushed antique gold metal<br>Metall Antik gold gebürstet<br>Métal brossé or antique<br>Metaal geborsteld antiek goud               |  |

### Rovere

#### Oak

|   |   |  |   |
|---|---|--|---|
| <b>OPR1</b><br>Rovere tinto ciliegio<br>Cherry stained oak<br>Eiche Kirschbaum gebeizt<br>Chêne teinté merisier<br>Eik kersenkleur                                    |    | <b>OPR8</b><br>Rovere tinto tabacco<br>Tobacco stained oak<br>Eiche tabak gebeizt<br>Chêne teinté tabac<br>Eik tabak                   |    |
| <b>OPR2</b><br>Rovere tinto wengé<br>Wengé stained oak<br>Eiche Wenge gebeizt<br>Chêne teinté wengé<br>Eik wengékleur   |    | <b>OPR9</b><br>Rovere tinto grigio tortora<br>Grey taupe stained oak<br>Eiche beige-grau gebeizt<br>Chêne teinté taupe<br>Eik taupe    |    |
| <b>OPR3</b><br>Rovere tinto noce<br>Walnut stained oak<br>Eiche Nussbaum gebeizt<br>Chêne teinté noyer<br>Eik notenkleur  |   | <b>OPR10</b><br>Rovere sbiancato<br>Whitened oak<br>Eiche gebleicht<br>Chêne blanchi<br>Eik gebleekt                                   |   |
| <b>OPR4</b><br>Rovere tinto naturale<br>Natural oak<br>Eiche natur farblos lackiert<br>Chêne naturel<br>Eik natuur  |  | <b>OPR11</b><br>Rovere tinto antracite<br>Charcoal stained oak<br>Eiche Anthrazit gebeizt<br>Chêne teinté anthracite<br>Eik antraciet  |  |
| <b>OPR5</b><br>Rovere tinto nero<br>Black stained oak<br>Eiche schwarz gebeizt<br>Chêne teinté noir<br>Eik zwart  |  | <b>OPR12</b><br>Rovere tinto mogano<br>Mahogany stained oak<br>Eiche mahagonifarbig gebeizt<br>Chêne teinté acajou<br>Eik mahoniekleur |  |
| <b>OPR6</b><br>Rovere tinto ciliegio Milano<br>Cherry Milano stained oak<br>Eiche Kirschbaum Milano gebeizt<br>Chêne teinté merisier Milano<br>Eik kersenkleur donker |  |  |   |

# Colori e finiture

## Colours and finishes

### Marmi e pietre

Marble and stone

#### OPP1

Marmo Carrara bianco lucido  
Shiny Carrara white marble  
Marmor Carrara weiss glänzend  
Marbre blanc Carrara brillant  
Marmer Carrara wit glanzend



#### OPP4

Pietra Serena grigia  
Grey Serena stone  
Grauer Serena Stein  
Pierre grise Serena  
Grijze steen Serena

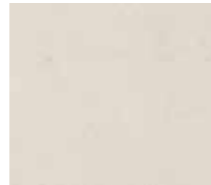

#### OPP2

Marmo nero Marquinia lucido  
Shiny Marquinia black marble  
Marmor Marquinia schwarz glänzend  
Marbre noir Marquinia brillant  
Marmer Marquinia zwart glanzend



#### OPP5

Pietra di Brera beige  
Beige Brera stone  
Beige Brera Stein  
Pierre beige Brera  
Beige steen Brera



#### OPP3

Marmo Emperador marrone lucido  
Shiny Emperador brown marble  
Marmor Emperador braun glänzend  
Marbre brung Emperador brillant  
Marmer Emperador bruin glanzend



#### OPP6

Marmo Perfetto brown opaco  
Matt Perfetto brown marble  
Marmor Perfetto braun matt  
Marbre brun Perfetto mat  
Marmer Perfetto bruin mat



#### OPP7

Marmo Calacatta oro lucido  
Shiny Calacatta gold marble  
Marmor Calacatta gold glänzend  
Marbre Calacatta or brillant  
Marmer Calacatta goud glanzend



### Finiture vetri

Glass finishes

#### OPV1

Vetro trasparente  
Transparent glass  
Klarglas  
Verre transparent  
Helder glas



#### OPV6

Vetro retroverniciato RAL 1019 beige grigiastro  
RAL 1019 grey beige back-painted glass  
RAL 1019 graubeige von hinten lackiertes Glas  
Verre laqué de dessous RAL 1019 beige gris  
Glas aan de onderkant gelakt RAL 1019 grijsbeige

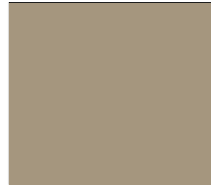

#### OPV2

Vetro satinato  
Frosted glass  
Mattglas  
Verre dépoli  
Melkglas



#### OPV7

Vetro retroverniciato nei colori RAL Classic  
Glass back-painted in the RAL Classic colours  
Von hinten lackiertes Glas in den RAL Classic Farben  
Verre laqué de dessous dans les couleurs RAL Classic  
Glas aan de onderkant gelakt in de RAL Classic-kleuren

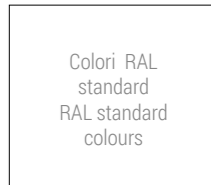

#### OPV3

Vetro retroverniciato RAL 9016 bianco traffico  
RAL 9016 traffic white back-painted glass  
RAL 9016 verkehrsweiß von hinten lackiertes Glas  
Verre laqué de dessous RAL 9016 blanc signalisation  
Glas aan de onderkant gelakt RAL 9016 verkeerswit



#### OPV9

Vetro bronzato retroverniciato cromo  
Chrome back-painted bronze glass  
Von hinten chromlackiertes Bronzenglas  
Verre bronzé laqué de dessous chrome  
Bronsglas aan de onderkant chroomgelakt

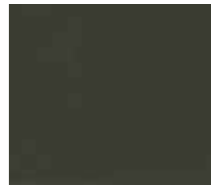

#### OPV4

Vetro retroverniciato RAL 9017 nero traffico  
RAL 9017 traffic black back-painted glass  
RAL 9017 verkehrsschwarz von hinten lackiertes Glas  
Verre laqué de dessous RAL 9017 noir signalisation  
Glas aan de onderkant gelakt RAL 9017 verkeerszwart



#### OPV10

Vetro grigio retroverniciato cromo  
Chrome back-painted grey glass  
Von hinten chromlackiertes Grauglas  
Verre gris laqué de dessous chrome  
Grijs glas aan de onderkant chroomgelakt

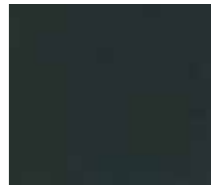

#### OPV5

Vetro retroverniciato RAL 7044 grigio seta  
RAL 7044 silk grey back-painted glass  
RAL 7044 seidengrau von hinten lackiertes Glas  
Verre laqué de dessous RAL 7044 gris soie  
Glas aan de onderkant gelakt RAL 7044 zijdegrijs



# Clip

Design Studio Marelli 2009



**marelli**





Tavolini **CLIP** 7CL101 ø cm 60x27h e 7CL102 ø cm 40x40h in metallo verniciato nei colori RAL 9017 nero traffico, RAL 9016 bianco traffico e RAL 1027 giallo curry.

***CLIP** coffee tables 7CL101 ø cm 60x27h and 7CL102 ø cm 40x40h in RAL 9017 traffic black, RAL 9016 traffic white and RAL 1027 curry painted metal.*



Tavolini **CLIP** 7CL107 ø cm 60x27h, 7CL108 ø cm 40x40h e 7CL109 ø cm 40x50h con base in metallo verniciato RAL 9017 nero traffico e top in vetro retroverniciato RAL 9017 nero traffico opaco.

**CLIP** coffee tables 7CL107 ø cm 60x27h, 7CL108 ø cm 40x40h and 7CL109 ø cm 40x50h with RAL 9017 traffic black painted metal base and RAL 9017 traffic black matt back-painted glass top.



Tavolino **CLIP** 7CL109 ø cm 40x50h con base in metallo verniciato RAL 9017 nero traffico e top in vetro retroverniciato RAL 9017 nero traffico lucido.

**CLIP** coffee table 7CL109 ø cm 40x50h with RAL 9017 traffic black painted metal base and RAL 9017 traffic black shiny back-painted glass top.

Tavolini **CLIP** 7CL107 ø cm 60x27h,  
7CL108 ø cm 40x40h e 7CL109 ø cm  
40x50h con base in metallo e top in vetro  
retroverniato nei colori RAL 1015 avorio  
chiaro e RAL 2000 arancio giallastro.

***CLIP** coffee tables 7CL107 ø cm 60x27h,  
7CL108 ø cm 40x40h and 7CL109 ø cm  
40x50h with metal base and back-painted  
glass top in the colours RAL 1015 light ivory  
and RAL 2000 yellow orange.*



Tavolino **CLIP** 7CL101 ø cm 60x27h in metallo verniciato RAL 9016 bianco traffico, 7CL102 ø cm 40x40h in metallo verniciato RAL 5015 blu cielo e 7CL103 ø cm 40x50h in metallo verniciato RAL 7006 grigio beige.

**CLIP** coffee table ø cm 60x27h in RAL 9016 traffic white painted metal, 7CL102 ø cm 40x40h in RAL 5015 sky blue painted metal and 7CL103 ø cm 40x50h in RAL 7006 beige grey painted metal.



# Clip

Design **Studio Marelli** 2009

Tavolini **CLIP** 7CL117 ø cm 40x40h e 7CL118 ø cm 40x50h in metallo spazzolato oro antico.

**CLIP** coffee tables 7CL117 ø cm 40x40h and 7CL118 ø cm 40x50h in antique gold brushed metal.



Base:  
metallo, spessore 5 mm  
Top:  
• metallo, spessore 5 mm  
Finiture metallo verniciato:  
· RAL 9017 nero traffico  
· RAL 9016 bianco traffico  
· RAL 7044 grigio seta  
· RAL 1019 beige grigiastro  
· RAL 7006 grigio beige  
· RAL 9006 alluminio brillante  
· classic bronze  
· golden beach  
· gold pearl  
· tutti gli altri colori RAL Classic  
Finiture metallo cromato o spazzolato:  
· cromo lucido  
· spazzolato cromo satinato  
· spazzolato canna di fucile  
· spazzolato rame  
· spazzolato ottone antico  
· cromo nero lucido  
· spazzolato oro antico  
• vetro extralight, temperato, spessore 6 mm, lucido o, su richiesta, opaco, retroverniciato nelle seguenti finiture:  
· RAL 9016 bianco traffico  
· RAL 9017 nero traffico  
· RAL 7044 grigio seta  
· RAL 1019 beige grigiastro  
· bronzato retroverniciato cromo  
· grigio retroverniciato cromo  
· tutti gli altri colori RAL Classic

Base:  
metal, 5 mm thick  
Top:  
• metal, 5 mm thick  
Finishes for painted metal:  
· RAL 9017 traffic black  
· RAL 9016 traffic white  
· RAL 7044 silk grey  
· RAL 1019 grey beige  
· RAL 7006 beige grey  
· RAL 9006 white aluminium  
· classic bronze  
· golden beach  
· gold pearl  
· all the other RAL Classic colours  
Finishes for chrome or brushed metal:  
· shiny chrome  
· brushed matt chrome  
· brushed matt dark grey  
· brushed copper  
· brushed antique brass  
· shiny black chrome  
· brushed antique gold  
• extralight glass, tempered, 6 mm thick, shiny or, on demand, matt, back-painted in the following finishes:  
· RAL 9016 traffic white  
· RAL 9017 traffic black  
· RAL 7044 silk grey  
· RAL 1019 grey beige  
· chrome back-painted bronze  
· chrome back-painted grey  
· all the other RAL Classic colours

Gestell:  
Metall, Stärke 5 mm  
Platte:  
• Metall, Plattenstärke 5 mm  
Ausführungen für lackiertes Metall:  
· RAL 9017 verkehrsschwarz  
· RAL 9016 verkehrsschwarz  
· RAL 7044 seidengrau  
· RAL 1019 graubeige  
· RAL 7006 beigegrau  
· RAL 9006 weissaluminium  
· classic bronze  
· golden beach  
· gold pearl  
· alle anderen RAL Classic-Farben  
Ausführungen für Metall verchromt oder gebürstet:  
· glänzend verchromt  
· matt verchromt (gebürstet)  
· dunkelgrau gebürstet  
· Kupfer gebürstet  
· Antik Messing gebürstet  
· schwarz glänzend verchromt  
· Antik gold gebürstet  
• Glas Extra Light, Sicherheitsglas, Glasplattenstärke 6 mm, glänzend oder, Auf Anfrage, matt, von hinten lackiert in den folgenden Ausführungen:  
· RAL 9016 verkehrsschwarz  
· RAL 9017 verkehrsschwarz  
· RAL 7044 seidengrau  
· RAL 1019 graubeige  
· von hinten chromlackiertes Bronzenglas  
· von hinten chromlackiertes Grauglas  
· alle anderen RAL Classic-Farben

# Clip

Design **Studio Marelli** 2009

- Structure:  
 métal, épaisseur 5 mm  
 Tablette:  
 • métal, épaisseur 5 mm  
 Finitions pour métal laqué:  
 · RAL 9017 noir signalisation  
 · RAL 9016 blanc signalisation  
 · RAL 7044 gris soie  
 · RAL 1019 beige gris  
 · RAL 7006 gris beige  
 · RAL 9006 aluminium blanc  
 · classic bronze  
 · golden beach  
 · gold pearl  
 · tous les autres coloris RAL Classic  
 Finitions pour métal chromé ou brossé:  
 · chromé brillant  
 · chromé mat (brossé)  
 · brossé canon de fusil  
 · brossé cuivre  
 · brossé laiton antique  
 · chromé noir brillant  
 · brossé or antique  
 · verre extra clair, trempé, épaisseur 6 mm, brillant ou, sur demande, mat, laqué de dessous dans les finitions suivantes:  
 · RAL 9016 blanc signalisation  
 · RAL 9017 noir signalisation  
 · RAL 7044 gris soie  
 · RAL 1019 beige gris  
 · bronzé laqué de dessous chrome  
 · gris laqué de dessous chrome  
 · alle anderen RAL Classic-Farben

- Frame:  
 metaal, dikte 5 mm  
 Blad:  
 • Metaal, dikte 5 mm  
 Afwerkingen voor gelakt metaal:  
 · RAL 9017 verkeerszwart  
 · RAL 9016 verkeerswit  
 · RAL 7044 zijdegrijs  
 · RAL 1019 grijsbeige  
 · RAL 7006 beigegrijs  
 · RAL 9006 blank aluminiumkleurig  
 · classic bronze  
 · golden beach  
 · gold pearl  
 · alle andere RAL Classic-kleuren  
 Afwerkingen voor verchromd of geborsteld metaal:  
 · glanschroom  
 · matchroom geborsteld  
 · canon de fusil geborsteld  
 · koper geborsteld  
 · antiek messing geborsteld  
 · glanschroom zwart  
 · antiek goud geborsteld  
 · extrahelder glas, getemperd, dikte 6 mm, glanzend of, op aanvraag, mat, aan de onderkant gelakt in de volgende afwerkingen:  
 · RAL 9016 verkeerswit  
 · RAL 9017 verkeerszwart  
 · RAL 7044 zijdegrijs  
 · RAL 1019 grijsbeige  
 · bronglas aan de onderkant chroomgelakt  
 · grijs glas aan de onderkant chroomgelakt  
 · alle andere RAL Classic-kleuren

- Каркас выполнен из металла толщиной 5м  
 Столешница:  
 • Металл толщиной 5мм  
 Варианты отделки для окрашенного металла  
 - RAL 9017 дорожно - черный  
 - RAL 9016 дорожно - белый  
 - RAL 7044 шелково – серый  
 - RAL 1019 бежево – серый  
 - RAL 7006 серо - бежевый  
 - RAL 9006 бело – алюминиевый  
 - бронзовый классический  
 - золотой песок (golden beach)  
 - золотой жемчуг (golden pearl)  
 - любой цвет из палитры RAL Classic  
 Варианты отделки для хромированного металла или металла spaццолато  
 - хром глянцевый  
 - хром сатинированный spaццолато (см. примечание)  
 - темно-серый (capna di fucile) spaццолато  
 - латунь spaццолато  
 - состаренная медь spaццолато  
 - хром черный глянцевый  
 - золото состаренное spaццолато  
 Примечание: spazzolato – вид отделки поверхности, при котором она обрабатывается специальными щетками, в результате чего создается декоративный эффект неровности.  
 • Закаленное стекло extra light толщиной 6мм, глянцевая отделка с тыльной стороны, по запросу возможна также и матовая, варианты:  
 - RAL 9016 дорожно - белый  
 - RAL 9017 дорожно - черный  
 - RAL 7044 шелково – серый  
 - RAL 1019 бежево – серый  
 - бронза, с тыльной стороны хром  
 - серый, с тыльной стороны хром  
 - любой цвет из палитры RAL Classic



|                               |                              |                              |                                  |                                   |                                   |  |                                |                            |                          |
|-------------------------------|------------------------------|------------------------------|----------------------------------|-----------------------------------|-----------------------------------|--|--------------------------------|----------------------------|--------------------------|
| <b>Code</b>                   | RAL 9017 black painted metal | RAL 9016 white painted metal | RAL 7044 silk grey painted metal | RAL 1019 grey beige painted metal | RAL 7006 beige grey painted metal | RAL 9006 white aluminium painted metal | Classic bronze painted metal   | Golden beach painted metal | Gold pearl painted metal |
| Painted metal table           | OPM6                         | OPM7                         |                                  |                                   |                                   |  | OPM9                           | OPM10                      | OPM11                    |
| <b>Code</b>                   | Shiny chrome metal           | Brushed matt chrome metal    | Brushed matt dark grey metal     | Brushed copper metal              | Brushed antique brass metal       | Shiny black chrome metal               | Brushed antique gold metal     |                            |                          |
| Chrome or brushed metal table | OPM1                         | OPM2                         | OPM3                             | OPM12                             | OPM13                             | OPM14                                  | OPM15                          |                            |                          |
| <b>Code</b>                   | RAL 9016 traffic white       | RAL 9017 traffic black       | RAL 7044 silk grey               | RAL 1019 grey beige               | Chrome back-painted bronze glass  |  | Chrome back-painted grey glass |                            |                          |
| Painted metal base +glass top | OPV3                         | OPV4                         | OPV5                             | OPV6                              | OPV9                              |  | OPV10                          |                            |                          |

# Frame

Design **Studio Marelli** 2009



Consolle **FRAME** 7FR130 cm 200x40x70h con struttura in metallo verniciato RAL 9017 nero, piano superiore in marmo Calacatta oro lucido e piano inferiore in vetro grigio retroverniciato cromo.

***FRAME** console 7FR130 cm 200x40x70h with RAL 9017 black painted metal structure, shiny Calacatta gold marble upper top and chrome back-painted grey glass lower top.*



Tavolini **FRAME** 7FR125 cm 100x100x28h  
con base in metallo cromo nero lucido e top  
in marmo Calacatta oro lucido.

**FRAME** coffee tables 7FR125 cm 100x100x28h  
with shiny black chrome metal base and shiny  
Calacatta gold marble top.





Tavolino **FRAME** 7FR121 ø cm 100x28h con base in metallo cromo nero lucido e top in marmo Emperador marrone lucido.

**FRAME** coffee table 7FR121 ø cm 100x28h with shiny black chrome metal base and shiny Emperador brown marble top.



Tavolini **FRAME** 7FR123 cm 70x70x28h con base in metallo spazzolato canna di fucie e top in marmo Emperador marrone lucido.

**FRAME** coffee tables 7FR123 cm 70x70x28h with brushed matt dark grey metal base and shiny Emperador brown marble top.



Consolle **FRAME** 7FR118 cm 160x40x70h, tavolino quadrato **FRAME** 7FR111 cm 70x70x28h, tavolino rettangolare **FRAME** 7FR112 cm 120x70x28h, totem **FRAME** 7FR117 cm 40x40x155h, tavolino **FRAME** 7FR116 cm 35x35x52h con basamenti in metallo satinato e piani in rovere tinto wengé.

***FRAME** Console 7FR118 cm 160x40x70h, **FRAME** square coffee table 7FR111 cm 70x70x28h, **FRAME** rectangular coffee table 7FR112 cm 120x70x28h, **FRAME** totem 7FR117 cm 40x40x155h, **FRAME** coffee table 7FR116 cm 35x35x52h with matt brushed metal bases and wengé stained oak tops.*





Libreria **FRAME** 7FR154 cm 130x40x155h con struttura in metallo verniciato RAL 7006 e piani in vetro retroverniciato RAL 7006.

**FRAME** bookshelf 7FR154 cm 130x40x155h with RAL 7006 painted metal structure and RAL 7006 back-painted glass tops.

Consolle **FRAME** 7FR108 cm 160x40x70h, server **FRAME** 7FR110 cm 55x27x51,5h, tavolino rettangolare **FRAME** 7FR102 cm 120x70x28h, totem **FRAME** 7FR107 cm 40x40x155h con basi in metallo verniciato RAL 9017 nero e piani in vetro retroverniciato RAL 1019 beige.

**FRAME** console 7FR108 cm 160x40x70h, **FRAME** server 7FR110 cm 55x27x51,5h, **FRAME** rectangular table 7FR102 cm 120x70x28h, **FRAME** totem 7FR107 cm 40x40x155h with RAL 9017 black painted metal structure and RAL 1019 beige back-painted glass tops.



Consolle **FRAME** 7FR108 cm 160x40x70h e tavolino 7FR104 ø cm 100x28h con base in metallo spazzolato ottone antico e top in vetro retroverniciato RAL 9016 bianco.

**FRAME** console 7FR108 cm 160x40x70h and table 7FR104 ø cm 100x28h with brushed antique brass metal base and RAL 9016 white back-painted metal base.

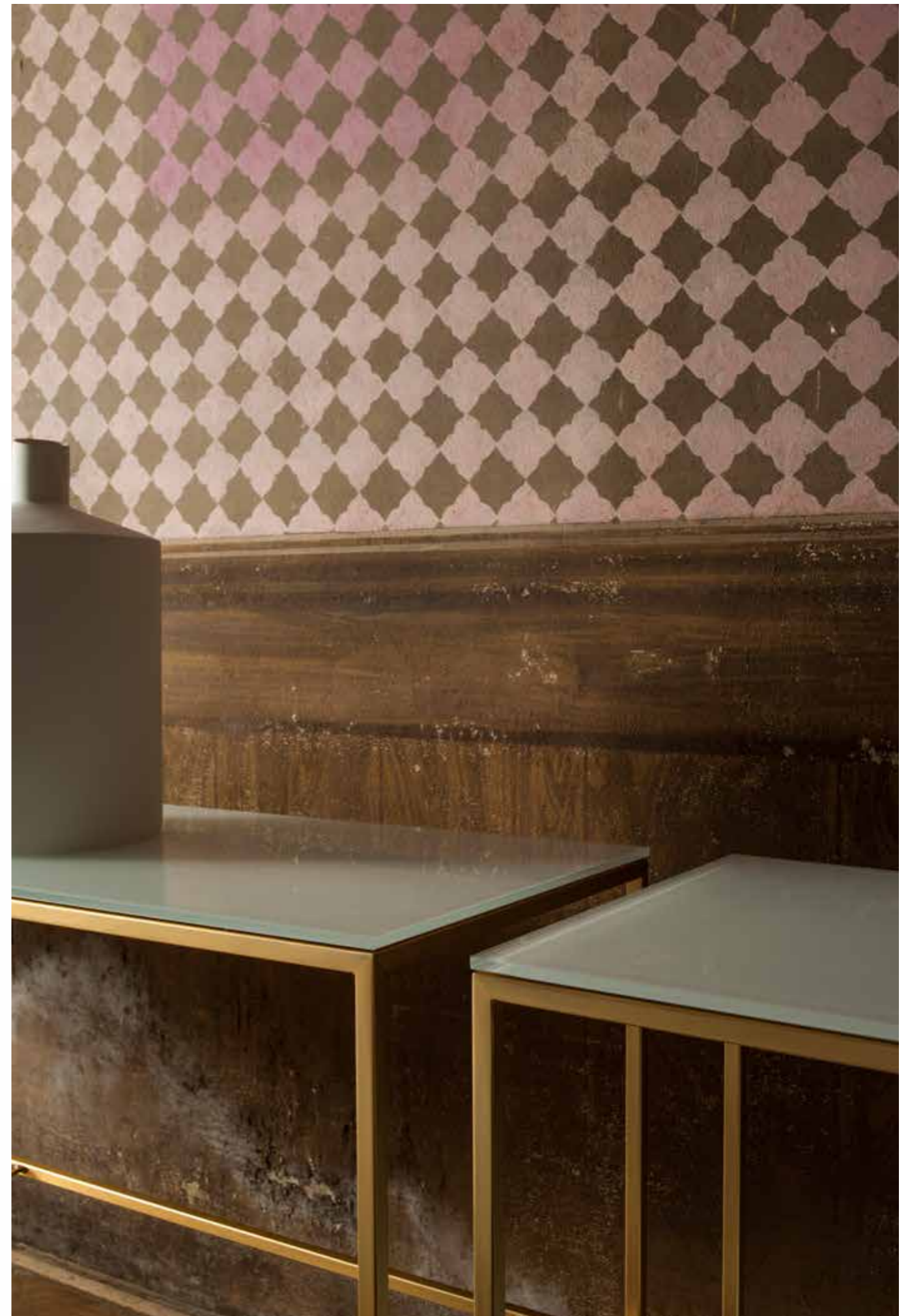

Tavolini **FRAME** 7FR104/7FR121 ø cm 100x28h con le seguenti finiture: base in metallo spazzolato cromo satinato e top in marmo Marquinia nero lucido, base in metallo spazzolato cromo satinato e top in vetro retroverniciato RAL 9017 nero, base in metallo verniciato RAL 9017 nero e top in vetro retroverniciato RAL 9017 nero.

**FRAME** tables 7FR104/7FR121 ø cm 100x28h in the following finishes: brushed matt chrome metal base and shiny Marquinia black marble top, brushed matt chrome metal base and RAL 9017 black back-painted glass top, RAL 9017 black painted metal base and RAL 9017 black back-painted glass top.



Tavolino **FRAME** 7FR104 ø cm 100x28h con base in metallo cromo lucido e top in vetro retroverniciato RAL 9016 bianco.

**FRAME** coffee table 7FR104 ø cm 100x28h with shiny chrome metal base and RAL 9016 white back-painted glass top.





Server **FRAME** 7FR127 cm 55x27x51,5h con base in metallo cromo lucido e top in marmo nero Marquinia lucido.

**FRAME** server 7FR127 cm 55x27x51,5h with shiny chrome metal base and shiny Marquinia black marble top.



Tavolini **FRAME** cm 35x35x52h in diverse finiture.

**FRAME** coffee tables cm 35x35x52h in different finishes.

# Frame

Design **Studio Marelli** 2009

Base:  
metallo, sezione 15 mm, disponibile nelle seguenti finiture:

- cromo lucido
- spazzolato cromo satinato
- spazzolato canna di fucile
- spazzolato rame
- spazzolato ottone antico
- cromo nero lucido
- spazzolato oro antico
- verniciato RAL 9017 nero traffico
- verniciato RAL 9016 bianco traffico
- verniciato classic bronze
- verniciato golden beach
- verniciato gold pearl
- verniciato in tutti gli altri colori RAL Classic

Piano:  
• vetro temperato extra light, spessore 6 mm, disponibile nelle seguenti finiture:

- vetro trasparente
- vetro satinato
- vetro lucido o opaco, retroverniciato nelle seguenti finiture:
- RAL 9016 bianco traffico
- RAL 9017 nero traffico
- RAL 7044 grigio seta
- RAL 1019 beige grigiastro
- bronzato retroverniciato cromo
- grigio retroverniciato cromo
- tutti gli altri colori RAL Classic disponibili su richiesta

• rovere europeo impiallacciato, spessore 10 mm

- marmo, spessore 14 mm, lucido o opaco, disponibile nei seguenti colori:
- bianco Carrara
- nero Marquinia
- marrone Emperador
- Perfetto brown
- Calacatta oro
- Black & Gold

Base:  
metal, section 15 mm, available in the following finishes:

- shiny chrome
- brushed matt chrome
- brushed matt dark grey
- brushed copper
- brushed antique brass
- shiny black chrome
- brushed antique gold
- painted RAL 9017 traffic black
- painted RAL 9016 traffic white
- painted classic bronze
- painted golden beach
- painted gold pearl
- painted in all other RAL Classic colours

Top:  
• tempered extra light glass, 6 mm thick, available in the following finishes:

- transparent glass
- frosted glass
- shiny or matt glass, back-painted in the following finishes:
- RAL 9016 traffic white
- RAL 9017 traffic black
- RAL 7044 silk grey
- RAL 1019 grey beige
- chrome back-painted bronze
- chrome back-painted grey
- all other RAL Classic colours available on demand

• European oak veneer, 10 mm thick

- marble, 14 mm thick, available in the following colours:
- Carrara white
- Marquinia black
- Emperador brown
- Perfetto brown
- Calacatta gold
- Black & Gold

Gestell:  
Metall, 4-Kant-Stahlrohr 15 x 15 mm, in den folgenden

Ausführungen erhältlich:

- glänzend verchromt
- matt verchromt gebürstet
- dunkelgrau gebürstet
- Kupfer gebürstet
- antik Messing gebürstet
- glänzend verchromt schwarz
- antik Gold gebürstet
- RAL 9017 verkehrsschwarz lackiert
- RAL 9016 Verkehrsweiß lackiert
- classic bronze lackiert
- golden beach lackiert
- gold pearl lackiert
- in allen anderen RAL Classic-Farben lackiert

Platte:

- gehärtetes Extra Light-Glas, Glasplattenstärke 6 mm, in den folgenden Ausführungen erhältlich:
- Klarglas
- Mattglas
- glänzendes oder mattes Glas, von hinten lackiert in den folgenden Ausführungen:
- RAL 9016 Verkehrsweiß
- RAL 9017 verkehrsschwarz
- RAL 7044 seidengrau
- RAL 1019 grau-beige
- Bronze von hinten chromlackiert
- grau von hinten chromlackiert
- alle anderen RAL Classic-Farben auf Anfrage erhältlich

• europäische Eiche furniert, Plattenstärke 10 mm

- Marmor, Plattenstärke 14 mm, in den folgenden Farben erhältlich:
- Carraraweiß
- Marquiniасhwarz
- Emperadorbraun
- Perfettobraun
- Calacatta Gold
- Black & Gold

Piètement:  
métal, section 15 mm, disponible dans les finitions suivantes:

- chromé brillant
- brossé chromé mat
- brossé canon de fusil
- brossé cuivre
- brossé laiton antique
- chromé brillant noir
- brossé or antique
- laqué RAL 9017 noir signalisation
- laqué RAL 9016 blanc signalisation
- laqué classic bronze
- laqué golden beach
- laqué gold pearl
- laqué dans toutes les autres couleurs RAL Classic

Plateau:

- verre trempé extra clair, épaisseur 6 mm, disponible dans les finitions suivantes:
- verre transparent
- verre dépoli
- verre brillant ou mat, laqué par dessous dans les finitions suivantes:
- RAL 9016 blanc signalisation
- RAL 9017 noir signalisation
- RAL 7044 gris soie
- RAL 1019 beige gris
- bronzé laqué au chrome par dessous
- gris laqué au chrome par dessous
- toutes les autres couleurs RAL Classic disponibles sur demande

• chêne européen plaqué, épaisseur 10 mm

- marbre, épaisseur 14 mm, disponible dans les couleurs suivantes:
- blanc Carrara
- noir Marquinia
- brun Emperador
- brun Perfetto
- or Calacatta
- Black & Gold

Onderstel:  
metaal, sectie 15 mm, verkrijgbaar in de volgende afwerkingen:

- glanschrom
- geborsteld matchroom
- geborsteld canon de fusil
- geborsteld koper
- geborsteld antiek messing
- glanschrom zwart
- geborsteld antiek goud
- RAL 9017 verkeerszwart gelakt
- RAL 9016 verkeerswit gelakt
- classic bronze gelakt
- golden beach gelakt
- gold pearl gelakt
- gelakt in alle andere RAL Classic-kleuren

Blad:

- getemperd extrahelder glas, bladdikte 6 mm, glanzend of mat, aan de onderkant gelakt in de volgende afwerkingen:
- helder glas
- matglas
- glanzend of mat, aan de onderkant gelakt in de volgende afwerkingen:
- RAL 9016 verkeerswit
- RAL 9017 verkeerszwart
- RAL 7044 zijdegrijs
- RAL 1019 grijsbeige
- brons aan de onderkant chroomgelakt
- grijs aan de onderkant chroomgelakt
- alle andere RAL Classic-kleuren op aanvraag verkrijgbaar

• Europese eik fineer, dikte 10 mm

- marmer, bladdikte 14 mm, glanzend of mat, verkrijgbaar in de volgende kleuren:
- Carrara White
- Marquinia Black
- Emperador Brown
- Perfetto Brown
- Calacatta Gold
- Black & Gold

Каркас выполнен из металла сечением 15мм,

варианты цветов отделки:

- хром глянцевый
- хром сатинированный спаццолато (см. примечание)
- темно-серый (canna di fucile) спаццолато
- латунь спаццолато
- состаренная медь спаццолато
- хром черный глянцевый
- золото состаренное спаццолато
- RAL 9017 дорожно · черный
- RAL 9016 дорожно – белый
- бронзовый
- золотой песок
- золотой жемчуг
- любой цвет по палитре RAL

Примечание: spazzolato – вид отделки поверхности, при котором она обрабатывается специальными щетками, в результате чего создается декоративный эффект неровности.

Stolешница:

- Закаленное стекло extra light толщиной 6мм, варианты:
- прозрачное
- сатинированное
- глянцевое либо матовое в следующих вариантах отделки с тыльной стороны
- RAL 9016 дорожно · белый
- RAL 9017 дорожно · черный
- RAL 7044 шелково – серый
- RAL 1019 бежево – серый
- бронза, с тыльной стороны хром
- серый, с тыльной стороны хром
- По запросу: любой цвет по шкале RAL Classic

• Массив дуба, фанерованный шпоном, толщина столешницы 10мм

- Мрамор, глянцевый либо матовый, толщиной 14мм, варианты:
- bianco Carrara
- nero Marquina
- marrone Emperador
- perfetto brown
- Calacatta oro
- Black and Gold

# Frame

Design **Studio Marelli** 2009

# Gordon

Design **Studio Marelli** 2014

**7FR101**  
Top in vetro / Glass top  
**7FR111**  
Top in legno / Wooden top  
**7FR123**  
Top in marmo / Marble top  
L70 P70 H28

**7FR102**  
Top in vetro / Glass top  
**7FR112**  
Top in legno / Wooden top  
**7FR124**  
Top in marmo / Marble top  
L120 P70 H28

**7FR103**  
Top in vetro / Glass top  
**7FR113**  
Top in legno / Wooden top  
**7FR125**  
Top in marmo / Marble top  
L100 P100 H28

**7FR131**  
Top in vetro / Glass top  
**7FR136**  
Top in legno / Wooden top  
**7FR139**  
Top in marmo / Marble top  
L70 P70 H40

**7FR132**  
Top in vetro / Glass top  
**7FR137**  
Top in legno / Wooden top  
**7FR140**  
Top in marmo / Marble top  
L120 P70 H40

**7FR133**  
Top in vetro / Glass top  
**7FR138**  
Top in legno / Wooden top  
**7FR141**  
Top in marmo / Marble top  
L100 P100 H40

**7FR104**  
Top in vetro / Glass top  
**7FR121**  
Top in marmo / Marble top  
Ø120 H28

**7FR105**  
Top in vetro / Glass top  
**7FR122**  
Top in marmo / Marble top  
Ø120 H28

**7FR134**  
Top in vetro / Glass top  
**7FR142**  
Top in marmo / Marble top  
Ø100 H40

**7FR135**  
Top in vetro / Glass top  
**7FR143**  
Top in marmo / Marble top  
Ø120 H40

**7FR151**  
Top in vetro / Glass top  
**7FR152**  
Top in legno / Wooden top  
**7FR153**  
Top in marmo / Marble top  
L50 P50 H50

**7FR154**  
Top in vetro / Glass top  
**7FR155**  
Top in legno / Wooden top  
**7FR156**  
Top in marmo / Marble top  
L130 P40 H155

**7FR107**  
Top in vetro / Glass top  
**7FR117**  
Top in legno / Wooden top  
**7FR128**  
Top in marmo / Marble top  
L40 P40 H155

**7FR108**  
Top in vetro / Glass top  
**7FR118**  
Top in legno / Wooden top  
**7FR129**  
Top in marmo / Marble top  
L160 P40 H70

**7FR109**  
Top in vetro / Glass top  
**7FR119**  
Top in legno / Wooden top  
**7FR130**  
Top in marmo / Marble top  
L200 P40 H70

**7FR110**  
Top in vetro / Glass top  
**7FR120**  
Top in legno / Wooden top  
**7FR127**  
Top in marmo / Marble top  
L55 P27 H51,5

**7FR144**  
Top in vetro / Glass top  
**7FR145**  
Top in legno / Wooden top  
**7FR146**  
Top in marmo / Marble top  
L55 P27 H51,5

**7FR106**  
Top in vetro / Glass top  
**7FR116**  
Top in legno / Wooden top  
**7FR126**  
Top in marmo / Marble top  
L35 P35 H52

|             |                          |                           |                              |                              |                              |                              |                            |                                  |                                |                      |                      |
|-------------|--------------------------|---------------------------|------------------------------|------------------------------|------------------------------|------------------------------|----------------------------|----------------------------------|--------------------------------|----------------------|----------------------|
|             | Transparent glass        | Frosted glass             | RAL 9016 white               | RAL 9017 black               | RAL 7044 silk grey           | RAL 1019 grey beige          | RAL standard colours       | Chrome Back-painted bronze glass | Chrome back-painted grey glass |                      |                      |
| <b>Code</b> | <b>OPV1</b>              | <b>OPV2</b>               | <b>OPV3</b>                  | <b>OPV4</b>                  | <b>OPV5</b>                  | <b>OPV6</b>                  | <b>OPV7</b>                | <b>OPV9</b>                      | <b>OPV10</b>                   |                      |                      |
| Glass top   | ●                        | ●                         | ●                            | ●                            | ●                            | ●                            | ●                          | ●                                | ●                              |                      |                      |
|             | Cherry stained oak       | Wengé stained oak         | Walnut stained oak           | Natural oak                  | Black stained oak            | Cherry Milano stained oak    | Tobacco stained oak        | Grey taupe stained oak           | Whitened oak                   | Charcoal stained oak | Mahogany stained oak |
| <b>Code</b> | <b>OPR1</b>              | <b>OPR2</b>               | <b>OPR3</b>                  | <b>OPR4</b>                  | <b>OPR5</b>                  | <b>OPR6</b>                  | <b>OPR8</b>                | <b>OPR9</b>                      | <b>OPR10</b>                   | <b>OPR11</b>         | <b>OPR12</b>         |
| Wooden top  | ●                        | ●                         | ●                            | ●                            | ●                            | ●                            | ●                          | ●                                | ●                              | ●                    | ●                    |
|             | White Carrara marble     | Black Marquina marble     | Brown Emperador marble       | Perfetto brown marble        | Calacatta gold marble        | Black and Gold marble        |                            |                                  |                                |                      |                      |
| <b>Code</b> | <b>OPP1</b>              | <b>OPP2</b>               | <b>OPP3</b>                  | <b>OPP6</b>                  | <b>OPP7</b>                  | <b>OPP9</b>                  |                            |                                  |                                |                      |                      |
| Marble top  | ●                        | ●                         | ●                            | ●                            | ●                            | ●                            |                            |                                  |                                |                      |                      |
|             | Shiny chromed metal      | Brushed matt chrome metal | Brushed matt dark grey metal | RAL 9017 black painted metal | RAL 9016 white painted metal | Classic bronze painted metal | Golden beach painted metal |                                  |                                |                      |                      |
| <b>Code</b> | <b>OPM1</b>              | <b>OPM2</b>               | <b>OPM3</b>                  | <b>OPM6</b>                  | <b>OPM7</b>                  | <b>OPM9</b>                  | <b>OPM10</b>               |                                  |                                |                      |                      |
| Metal base  | ●                        | ●                         | ●                            | ●                            | ●                            | ●                            | ●                          |                                  |                                |                      |                      |
|             | Gold pearl painted metal | Brushed copper metal      | Brushed antique brass metal  | Shiny black chrome metal     | Brushed antique gold metal   |                              |                            |                                  |                                |                      |                      |
| <b>Code</b> | <b>OPM11</b>             | <b>OPM12</b>              | <b>OPM13</b>                 | <b>OPM14</b>                 | <b>OPM15</b>                 |                              |                            |                                  |                                |                      |                      |
| Metal base  | ●                        | ●                         | ●                            | ●                            | ●                            |                              |                            |                                  |                                |                      |                      |



**marelli**



Divano **GORDON T** 9GT206 cm 250x100x86h con cuscini con fascia 9G0107 cm 45x45 in tessuto cat. E art. San Mateo col. 17 e piedi in metallo verniciati classic bronze. Cuscino con fascia 9G0107 cm 45x45 e cuscino a saponetta 9CU103 cm 40x40 in pelle cat. Super art. Dollaro col. 7110. Pouf **LOUNGE** trapuntato cm 94x120x38h in pelle cat. Super art. Dollaro col. 7110. Tavolini **TWINS** 7TW101 ø cm 51x37h e 7TW102 ø cm 51x51h in rovere tinto antracite e tavolino **STONE** 7ST110 cm 95x95x27h con base in

rovere tinto antracite e top in marmo Perfetto Brown opaco. Poltrona **RIBOT** 9RB101 cm 78x103x89h in tessuto cat. E art. San Mateo col. 17 con parte esterna in pelle cat. Super art. Dollaro col. 7110. Consolle **FRAME** 7FR130 cm 200x40x70h con struttura in metallo verniciato nero, piano superiore in marmo Calacatta oro lucido e piano inferiore in vetro grigio retroverniciato cromo. Specchi **MIRROR** 7MR104 cm 100x3x200h in pelle cat. Super art. Dollaro col. 7150 nero.

**GORDON T** sofa 9GT206 cm 250x100x86h with cushions with band 9G0107 cm 45x45 in fabric cat. E art. San Mateo col. 17 and classic bronze painted metal feet. Cushion with band 9G0107 cm 45x45 and cushion without band 9CU103 cm 40x40 in leather cat. Super art. Dollaro col. 7110. Quilted **LOUNGE** pouf cm 94x120x38h in leather cat. Super art. Dollaro col. 7110. **TWINS** coffee tables 7TW101 ø cm 51x37h and 7TW102 ø cm 51x51h in charcoal stained oak and **STONE** table 7ST110 cm 95x95x27h with

charcoal stained oak base and matt Perfetto brown marble top. **RIBOT** armchair 9RB101 cm 78x103x89h in fabric cat. E art. San Mateo col. 17 with external part in fabric cat. Super art. Dollaro col. 7110. **FRAME** console 7FR130 cm 200x40x70h with black painted meta structure, shiny Calacatta gold upper top and chrome back-painted grey glass top. **MIRROR** mirrors 7MR104 cm 100x3x200h in leather cat. Super art. Dollaro col. 7150 black.





Divano **GORDON T** 9GT206 cm 250x100x86h con cuscini con fascia 9G0107 cm 45x45 in tessuto cat. E art. San Mateo col. 17 e piedi in metallo verniciati classic bronze. Cuscino con fascia 9G0107 cm 45x45 e cuscino a saponetta 9CU103 cm 40x40 in pelle cat. Super art. Dollaro col. 7110. Tavolini **TWINS** 7TW101 ø cm 51x37h e 7TW102 ø cm 51x51h in rovere tinto antracite e tavolino **STONE** 7ST110 cm 95x95x27h con base in rovere tinto antracite e top in marmo Perfetto Brown opaco.

**GORDON T** sofa 9GT206 cm 250x100x86h with cushions with band 9G0107 cm 45x45 in fabric cat. E art. San Mateo col. 17 and classic bronze painted metal feet. Cushion with band 9G0107 cm 45x45 and cushion without band 9CU103 cm 40x40 in leather cat. Super art. Dollaro col. 7110. **TWINS** coffee tables 7TW101 ø cm 51x37h and 7TW102 ø cm 51x51h in charcoal stained oak and **STONE** table 7ST110 cm 95x95x27h with charcoal stained oak base and matt Perfetto brown marble top.



Tavolini **TWINS** 7TW101 ø cm 51x37h e 7TW102 ø cm 51x51h, 7TW111 cm 45x45x37h e 7TW112 cm 45x45x51h in rovere tinto antracite.

**TWINS** coffee tables 7TW101 ø cm 51x37h and 7TW102 ø cm 51x51h, 7TW111 cm 45x45x37h and 7TW112 cm 45x45x51h in charcoal stained oak.

Composizione **GORDON** cm 313x225 in tessuto cat. E art. Catria col. 18 con cuscini con fascia 9G0107 cm 45x45 nello stesso tessuto, cuscino a saponetta trapuntato 9CUT104 cm 60x60 in tessuto cat. F art. Lario col. 2012 e 9CUT103 cm 40x40 in tessuto cat. F art. Lario col. 02 con piedini in metallo cromato lucido. Tavolino **PLANET** 7PL101 cm 95x95x25h in MDF laccato nero lucido. Tavolini **FRAME** 7FR123 cm 70x70x28h e server **FRAME** 7FR127 cm 55x27x51,5h con base in metallo spazzolato canna di fucile e top in marmo Emperor marrone lucido. Tavolino **STONE** 7ST118 cm 120x45x27h con base in rovere tinto nero e top in vetro grigio retroverniciato cromo.

**GORDON** composition cm 313x225 in fabric cat. E art. Catria col. 18 with cushions with band 9G0107 cm 45x45 in the same fabric, quilted cushion without band 9CUT104 cm 50x50 in fabric cat. F art. Lario col. 2012 and 9CUT103 cm 40x40 in fabric cat. F art. Lario col. 02 with shiny chrome metal feet. **PLANET** coffee table 7PL101 cm 95x95x25h in glossy black lacquered MDF. **FRAME** coffee tables 7FR123 cm 70x70x28h and server 7FR127 cm 55x27x51,5h with brushed matt dark grey metal base and shiny Emperor brown marble top. **STONE** table 7ST118 cm 120x45x27h with black painted oak base and chrome back-painted grey glass.

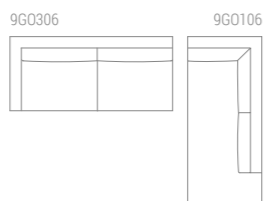



Composizione **GORDON** cm 313x225 in tessuto cat. E art. Catria col. 18 con cuscini con fascia 9G0107 cm 45x45 nello stesso tessuto, cuscino a saponetta trapuntato 9CUT104 cm 60x60 in tessuto cat. F art. Lario col. 2012 e 9CUT103 cm 40x40 in tessuto cat. F art. Lario col. 02 con piedini in metallo cromato lucido. Poltroncine **ASCOT** trapuntate 9AS101 cm 72x72x70h

con base 0 in rovere tinto wengè. Tavolino **PLANET** 7PL101 cm 95x95x25h in MDF laccato nero lucido. Tavolini **FRAME** 7FR123 cm 70x70x28h e server **FRAME** 7FR127 cm 55x27x51,5h con base in metallo spazzolato canna di fucile e top in marmo Emperador marrone lucido. Tavolino **STONE** 7ST118 cm 120x45x27h con base in rovere tinto nero e top in vetro grigio retroverniciato cromo.

**GORDON** composition cm 313x225 in fabric cat. E art. Catria col. 18 with cushions with band 9G0107 cm 45x45 in the same fabric, quilted cushion without band 9CUT104 cm 60x60 in fabric cat. F art. Lario col. 2012 and 9CUT103 cm 40x40 in fabric cat. F art. Lario col. 02 with shiny chrom metal feet. Quilted **ASCOT** armchairs 9AS101 cm 72x72x70h with base 0 in wengè stained oak. **PLANET**

coffee table 7PL101 cm 95x95x25h in glossy black lacquered MDF. **FRAME** coffee tables 7FR123 cm 70x70x28h and server 7FR127 cm 55x27x51,5h with brushed matt dark grey metal base and shiny Emperador brown marble top. **STONE** table 7ST118 cm 120x45x27h with black painted oak base and chrome back-painted grey glass.

9G0306



9G0106



Composizione **GORDON T** cm 340x325, pouf 9GT111 cm 100x100x40h e cuscini con fascia 9G0107 cm 45x45 e senza fascia 9CU103 cm 40x40 in pelle cat. Lusso art. Nabuk 3M col. Conchiglia e cuscinetti a saponetta 9CU103 cm 40x40 in tessuto cat. H art. S015.5. Piedini in metallo verniciato classic bronze. Tavolino **CLIP** 7CL103 ø cm

40x50h in metallo spazzolato ottone antico, tavolino **STONE** 7ST112 cm 120x45x27h con base in rovere tinto wengè e top in marmo Calacatta oro lucido. Libreria **FRAME** 7FR154 cm 130x40x155h con struttura in metallo verniciato RAL 7006 e piani in vetro retroverniciato RAL 7006.

**GORDON T** composition cm 340x325, pouf 9GT111 cm 100x100x40h and cushions with band 9G0107 cm 45x45 and without band 9CU103 cm 40x40 in leather cat. Lusso art. Nabuk 3M col. Conchiglia and cushions without band 9CU103 cm 40x40 in fabric cat. H art. S015.5. Classic bronze painted metal feet. **CLIP**

coffee table 7CL103 ø cm 40x50h in brushed antique brass metal, **STONE** table 7ST112 cm 120x45x27h with wengè stained oak base and shiny Calacatta gold marble top. **FRAME** bookshelf 7FR154 cm 130x40x155h with RAL 7006 painted metal structure and RAL 7006 back-painted glass tops.

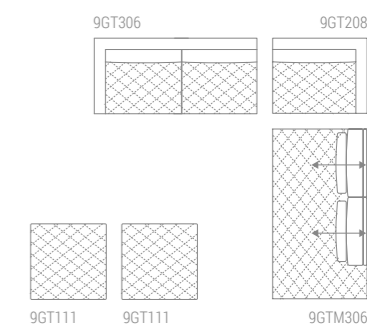

Composizione **GORDON T** cm 340x325, pouf 9GT111 cm 100x100x40h e cuscini con fascia 9G0107 cm 45x45 e senza fascia 9CU103 cm 40x40 in pelle cat. Lusso art. Nabuk 3M col. Conchiglia e cuscinetti a saponetta 9CU103 cm 40x40 in tessuto cat. H art. S015.5. Piedini in metallo verniciato classic bronze. Poltrona **RIBOT** 9RB103 con schienale basso cm 78x103x68h in pelle cat.

Super art. Dollaro col. 7140. Tavolino **CLIP** 7CL103 ø cm 40x50h in metallo spazzolato ottone antico, tavolino **CIRCLE** 7CR108 ø cm 60x40h con base in metallo spazzolato oro antico e top in marmo Emperador marrone lucido. Tavolo **FRAME** 7FR121 ø cm 100x28h con base in metallo cromo nero lucido e top in marmo Emperador marrone lucido. Tavolino **BREAK** 7BR102 ø cm 60x36h con

base in metallo spazzolato ottone antico e top in marmo Emperador marrone lucido. Tavolino **CIRCLE** 7CR102 ø cm 60x40h con base in metallo cromo nero lucido e top in vetro bronzato retroverniciato cromo. Libreria **FRAME** 7FR154 cm 130x40x155h con struttura in metallo verniciato RAL 7006 e piani in vetro retroverniciato RAL 7006.

**GORDON T** composition cm 340x325, pouf 9GT111 cm 100x100x40h and cushions with band 9G0107 cm 45x45 and without band 9CU103 cm 40x40 in leather cat. Lusso art. Nabuk 3M col. Conchiglia and cushions without band 9CU103 cm 40x40 in fabric cat. H art. S015.5. Classic bronze painted metal feet. **RIBOT** armchair 9RB103 with low back cm

78x103x68h in leather cat. Super art. Dollaro col. 7140. **CLIP** coffee table 7CL103 ø cm 40x50h in brushed antique brass metal, **CIRCLE** coffee table 7CR108 ø cm 60x40h with brushed antique gold metal base and shiny Emperador brown marble top. **FRAME** table 7FR121 ø cm 100x28h with shiny black chrome metal base and shiny Emperador brown marble top. **BREAK**

coffee table 7BR102 ø cm 60x36h with brushed antique brass metal base and shiny Emperador brown marble top. **CIRCLE** coffee table 7CR102 ø cm 60x40h with shiny black chrome metal base and chrome back-painted bronze glass. **FRAME** bookshelf 7FR154 cm 130x40x155h with RAL 7006 painted metal structure and RAL 7006 back-painted glass tops.

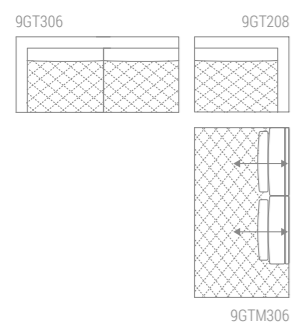

Composizione **GORDON T** cm 340x325, pouf 9GT111 cm 100x100x40h e cuscini con fascia 9G0107 cm 45x45 e senza fascia 9CU103 cm 40x40 in pelle cat. Lusso art. Nabuk 3M col. Conchiglia e cuscinetti a saponetta 9CU103 cm 40x40 in tessuto cat. H art. S015.5. Piedini in metallo verniciato classic bronze. Poltrona **RIBOT** 9RB103 con schienale basso cm

78x103x68h in pelle cat. Super art. Dollaro col. 7140. Tavolini **CLIP** 7CL103 ø cm 40x50h e 7CL102 ø cm 40x40h in metallo spazzolato ottone antico, tavolino **CIRCLE** 7CR108 ø cm 60x40h con base in metallo spazzolato oro antico e top in marmo Emperador marrone lucido. Tavolo **FRAME** 7FR121 ø cm 100x28h con base in metallo cromo nero lucido e

top in marmo Emperador marrone lucido. Tavolino **BREAK** 7BR102 ø cm 60x36h con base in metallo spazzolato ottone antico e top in marmo Emperador marrone lucido. Libreria **FRAME** 7FR154 cm 130x40x155h con struttura in metallo verniciato RAL 7006 e piani in vetro retroverniciato RAL 7006.

**GORDON T** composition cm 340x325, pouf 9GT111 cm 100x100x40h and cushions with band 9G0107 cm 45x45 and without band 9CU103 cm 40x40 in leather cat. Lusso art. Nabuk 3M col. Conchiglia and cushions without band 9CU103 cm 40x40 in fabric cat. H art. S015.5. Classic bronze painted metal feet. **RIBOT** armchair 9RB103 with

low back cm 78x103x68h in leather cat. Super art. Dollaro col. 7140. **CLIP** coffee tables 7CL103 ø cm 40x50h and 7CL102 ø cm 40x40h in brushed antique brass metal, **CIRCLE** coffee table 7CR108 ø cm 60x40h with brushed antique gold metal base and shiny Emperador brown marble top. **FRAME** table 7FR121 ø cm 100x28h with shiny black

chrome metal base and shiny Emperador brown marble top. **BREAK** coffee table 7BR102 ø cm 60x36h with brushed antique brass metal base and shiny Emperador brown marble top. **FRAME** bookshelf 7FR154 cm 130x40x155h with RAL 7006 painted metal structure and RAL 7006 back-painted glass tops.

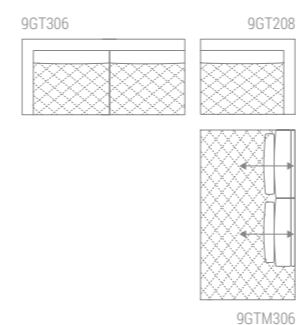

Dettaglio di divano **GORDON T** in pelle cat. Lusso art. Nabuk 3M col. Conchiglia e tavolino **CIRCLE** 7CR102 ø cm 60x40h con base in metallo cromo nero lucido e top in vetro bronzato retroverniciato cromo.

Detail of **GORDON T** sofa in leather cat. Lusso art. Nabuk 3M col. Conchiglia and **CIRCLE** coffee table 7CR102 ø cm 60x40h with shiny black chrome metal base and chrome back-painted bronze glass.

# Gordon

Design **Studio Marelli** 2014

Divani Sofas

Elementi componibili Modular elements

Divani letto Sofa-beds

Dormeuse Longchair

Pouf e accessori Pouf and accessories

Piedini Feet

Elemento angolare Corner element

Elemento angolare Corner element

9GO101 L90 P100 H86

9GO301 L115 P100 H86

9GO207 L100 P100 H86

9GO202 L170 P100 H86

9GO302 L135 P100 H86

9GO208 L125 P100 H86

9GO401 L100 P100 H86

9GO213 L190 P100 H86

Materasso Mattress L115 P190 H15

9GO214 L210 P100 H86

Materasso Mattress L145 P190 H15

9GO203 L190 P100 H86

9GO303 L155 P100 H86

9GO402 L140 P100 H86

9GO215 L230 P100 H86

Materasso Mattress L160 P190 H15

9GO204 L210 P100 H86

9GO304 L175 P100 H86

9GO403 L160 P100 H86

9GO216 L250 P100 H86

Materasso Mattress L160 P190 H15

9GO205 L230 P100 H86

9GO305 L195 P100 H86

9GO404 L180 P100 H86

9GO314 L175 P100 H86

Materasso Mattress L115 P190 H15

9GO206 L250 P100 H86

9GO306 L215 P100 H86

9GO405 L200 P100 H86

9GO315 L195 P100 H86

Materasso Mattress L145 P190 H15

9GO316 L215 P100 H86

Materasso Mattress L160 P190 H15

80 80

9GO102 L180 P98 H86

9GO110 L100 P75 H40

9CU103 L40 H40

Cuscinetto in piuma senza fascia Feather cushion without band

80 80

9GO103 L180 P98 H86

9GO111 L100 P100 H40

9CU105 L50 H50

Cuscinetto in piuma senza fascia Feather cushion without band

55 55

9GO104 L200 P98 H86

9GO112 L100 P125 H40

9CUT103 L40 H40

Cuscinetto trapuntato in piuma senza fascia Quilted feather cushion without band

80 80

9GO105 L200 P98 H86

9CUT104 L60 H60

Cuscinetto trapuntato in piuma senza fascia Quilted feather cushion without band

45 45

9GO106 L225 P98 H86

9GO107 L45 H45

Cuscinetto in piuma con fascia Feather cushion with band

90 100  
60 63  
15

| Feet code | Shiny chrome metal OPM1   | Brushed matt chrome metal OPM2 | Matt brushed dark grey metal OPM3 | RAL 9017 black painted metal OPM6 | Classic bronze painted metal OPM9 | Brushed copper metal OPM12       | Brushed antique brass metal OPM13 | Shiny black chrome metal OPM14 | Brushed antique gold metal OPM15 |                              |
|-----------|---------------------------|--------------------------------|-----------------------------------|-----------------------------------|-----------------------------------|----------------------------------|-----------------------------------|--------------------------------|----------------------------------|------------------------------|
| Version A | ●                         | ●                              | ●                                 | ●                                 | ●                                 | ●                                | ●                                 | ●                              | ●                                |                              |
| Feet code | Cherry stained beech OPF1 | Wengé stained beech OPF2       | Walnut stained beech OPF3         | Natural beech OPF4                | Black stained beech OPF5          | Cherry Milano stained beech OPF6 | Tobacco stained beech OPF8        | Grey taupe stained beech OPF9  | Charcoal stained beech OPF11     | Mahogany stained beech OPF12 |
| Version B | ●                         | ●                              | ●                                 | ●                                 | ●                                 | ●                                | ●                                 | ●                              | ●                                |                              |



# GordonMove

Design **Studio Marelli** 2014

## Divani Sofas

## Elementi componibili Modular elements

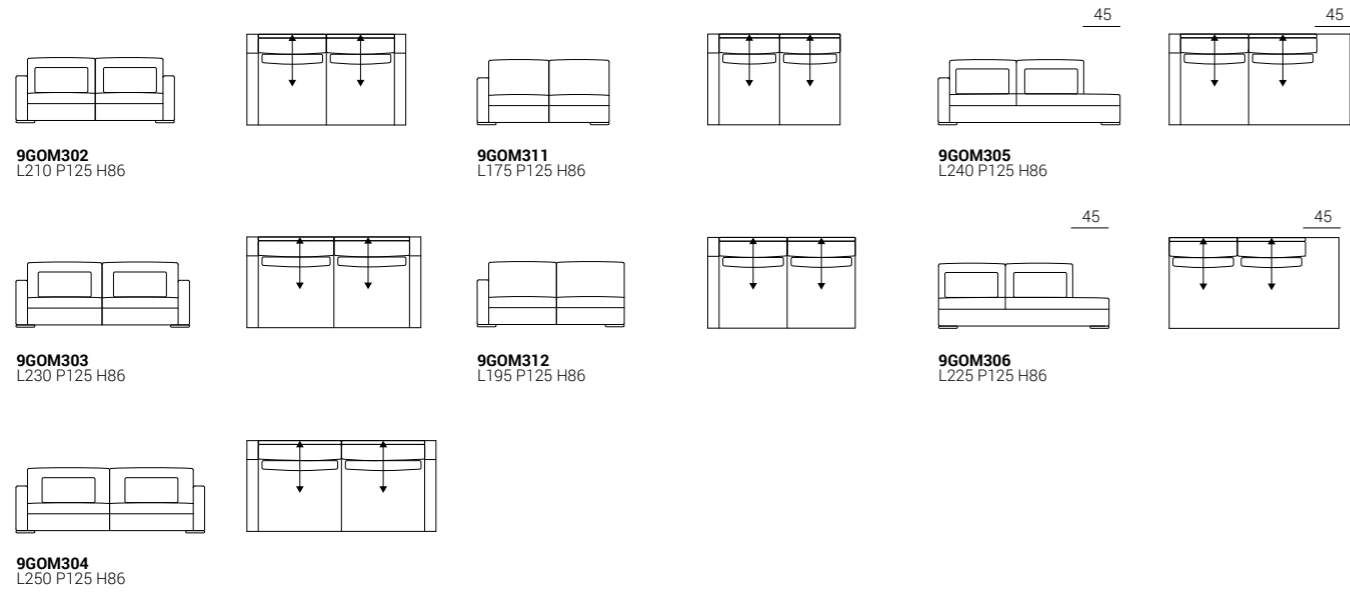

## Pouf e accessori Pouf and accessories

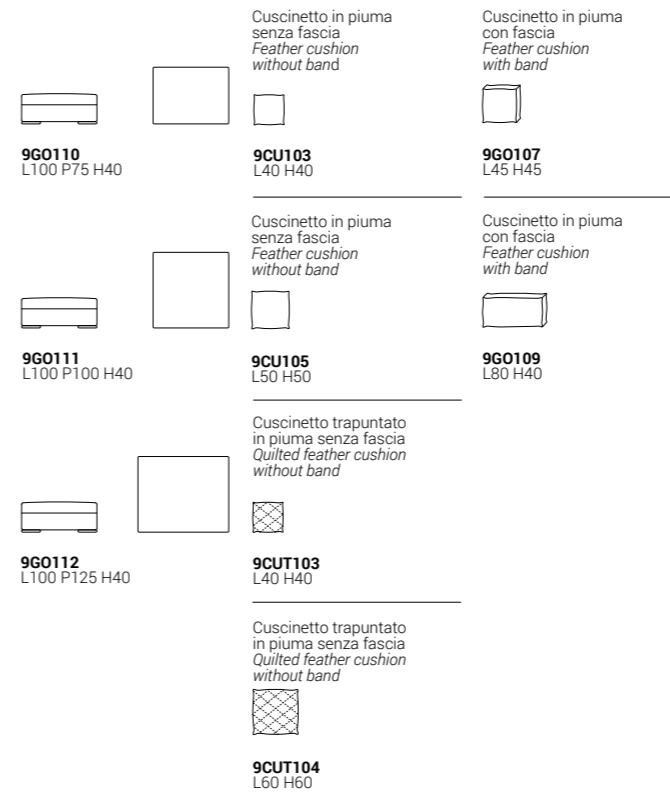

## Piedini Feet

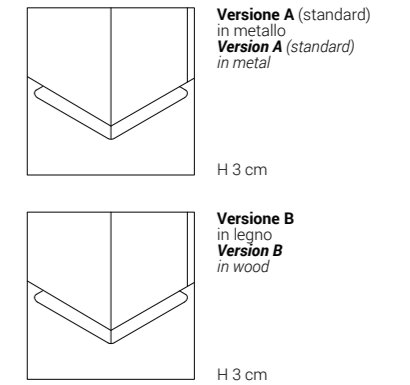

*Gli elementi componibili Gordon Move possono essere liberamente combinati con gli elementi Gordon per creare infinite composizioni*

*The different elements of Gordon Move can be combined with the modular elements of Gordon to create several and different compositions*

## Movimento schienali Backrest mechanism



| Feet code | Shiny chrome metal<br>OPM1   | Brushed matt chrome metal<br>OPM2 | Matt brushed dark grey metal<br>OPM3 | RAL 9017 black painted metal<br>OPM6 | Classic bronze painted metal<br>OPM9 | Brushed copper metal<br>OPM12       | Brushed antique brass metal<br>OPM13 | Shiny black chrome metal<br>OPM14 | Brushed antique gold metal<br>OPM15 |                                 |
|-----------|------------------------------|-----------------------------------|--------------------------------------|--------------------------------------|--------------------------------------|-------------------------------------|--------------------------------------|-----------------------------------|-------------------------------------|---------------------------------|
| Version A | ●                            | ●                                 | ●                                    | ●                                    | ●                                    | ●                                   | ●                                    | ●                                 | ●                                   |                                 |
| Feet code | Cherry stained beech<br>OPF1 | Wengé stained beech<br>OPF2       | Walnut stained beech<br>OPF3         | Natural beech<br>OPF4                | Black stained beech<br>OPF5          | Cherry Milano stained beech<br>OPF6 | Tobacco stained beech<br>OPF8        | Grey taupe stained beech<br>OPF9  | Charcoal stained beech<br>OPF11     | Mahogany stained beech<br>OPF12 |
| Version B | ●                            | ●                                 | ●                                    | ●                                    | ●                                    | ●                                   | ●                                    | ●                                 | ●                                   | ●                               |

# GordonQuilted

Design **Studio Marelli** 2014

Divani  
Sofas

Elementi componibili  
Modular elements

Divani letto  
Sofa-beds

Dormeuse  
Longchair

Pouf e accessori  
Pouf and accessories

Piedini  
Feet

Elemento angolare  
Corner element

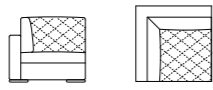

9GT101 L90 P100 H86

9GT301 L115 P100 H86

9GT207 L100 P100 H86

Elemento angolare  
Corner element

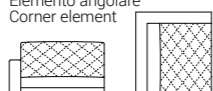

9GT202 L170 P100 H86

9GT302 L135 P100 H86

9GT208 L125 P100 H86

9GT401 L100 P100 H86

9GT213 L190 P100 H86

Materasso  
Mattress  
L115 P190 H15

225

9GT214 L210 P100 H86

Materasso  
Mattress  
L145 P190 H15

225

9GT215 L230 P100 H86

Materasso  
Mattress  
L160 P190 H15

225

9GT216 L250 P100 H86

Materasso  
Mattress  
L160 P190 H15

225

9GT314 L175 P100 H86

Materasso  
Mattress  
L115 P190 H15

225

9GT315 L195 P100 H86

Materasso  
Mattress  
L145 P190 H15

225

9GT316 L215 P100 H86

Materasso  
Mattress  
L160 P190 H15

225

80

80

9GT102 L180 P98 H86

9GT110 L100 P75 H40

Cuscinetto in piuma senza fascia  
Feather cushion without band

9CU103 L40 H40

Versione A (standard)  
in metallo  
Version A (standard)  
in metal

H 3 cm

Versione B  
in legno  
Version B  
in wood

H 3 cm

55

55

9GT103 L180 P98 H86

9GT111 L100 P100 H40

Cuscinetto in piuma senza fascia  
Feather cushion without band

9CU105 L50 H50

55

55

9GT104 L200 P98 H86

9GT112 L100 P125 H40

Cuscinetto trapuntato in piuma senza fascia  
Quilted feather cushion without band

9CU103 L40 H40

80

80

9GT105 L200 P98 H86

9GT107 L45 H45

Cuscinetto trapuntato in piuma senza fascia  
Quilted feather cushion without band

9CU104 L60 H60

45

45

9GT106 L225 P98 H86

9GO107 L80 H40

Cuscinetto in piuma con fascia  
Feather cushion with band

9GO109 L80 H40

90 100  
60 63  
15

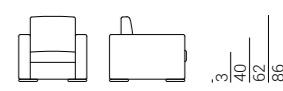

| Foot code | Shiny chrome metal<br>OPM1   | Brushed matt chrome metal<br>OPM2 | Matt brushed dark grey metal<br>OPM3 | RAL 9017 black painted metal<br>OPM6 | Classic bronze painted metal<br>OPM9 | Brushed copper metal<br>OPM12       | Brushed antique brass metal<br>OPM13 | Shiny black chrome metal<br>OPM14 | Brushed antique gold metal<br>OPM15 |                                 |
|-----------|------------------------------|-----------------------------------|--------------------------------------|--------------------------------------|--------------------------------------|-------------------------------------|--------------------------------------|-----------------------------------|-------------------------------------|---------------------------------|
| Version A | ●                            | ●                                 | ●                                    | ●                                    | ●                                    | ●                                   | ●                                    | ●                                 | ●                                   |                                 |
| Foot code | Cherry stained beech<br>OPF1 | Wengé stained beech<br>OPF2       | Walnut stained beech<br>OPF3         | Natural beech<br>OPF4                | Black stained beech<br>OPF5          | Cherry Milano stained beech<br>OPF6 | Tobacco stained beech<br>OPF8        | Grey taupe stained beech<br>OPF9  | Charcoal stained beech<br>OPF11     | Mahogany stained beech<br>OPF12 |
| Version B | ●                            | ●                                 | ●                                    | ●                                    | ●                                    | ●                                   | ●                                    | ●                                 | ●                                   |                                 |

# Gordon Move Quilted

Design **Studio Marelli** 2014

Divani  
Sofas

Elementi componibili  
Modular elements

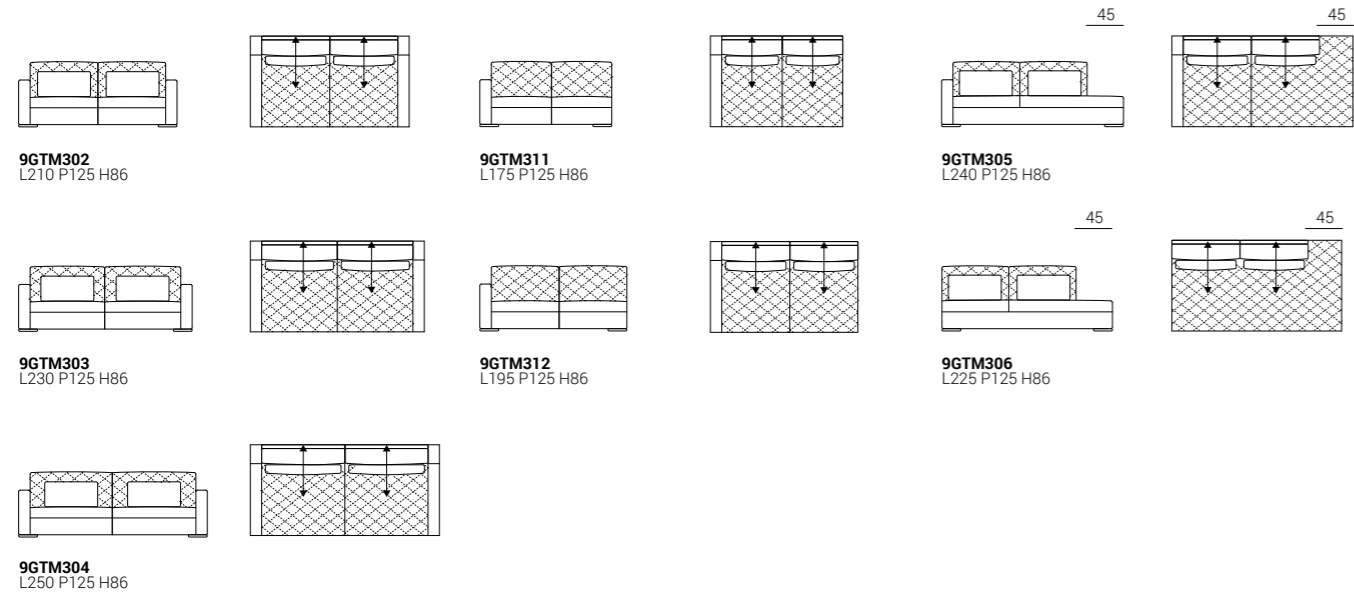

Pouf e accessori  
Pouf and accessories

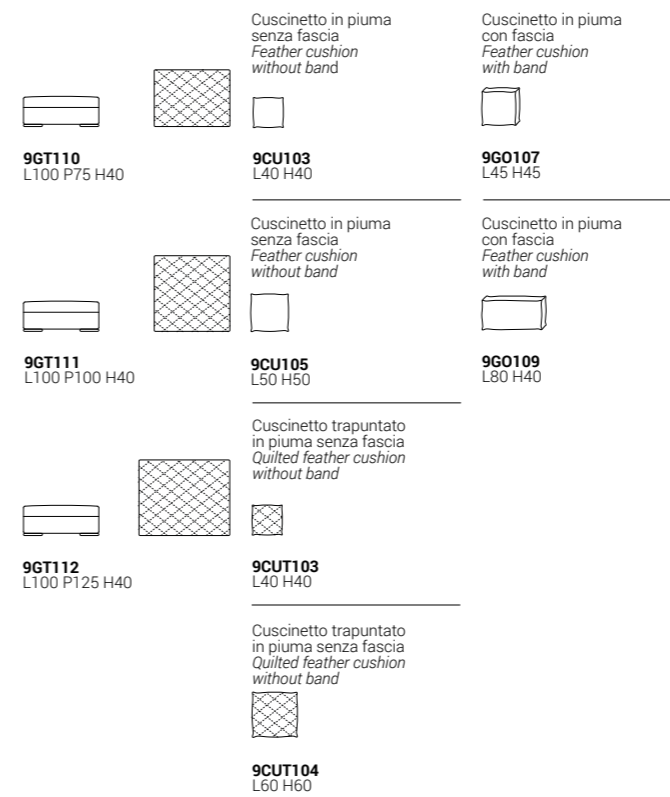

Piedini  
Feet

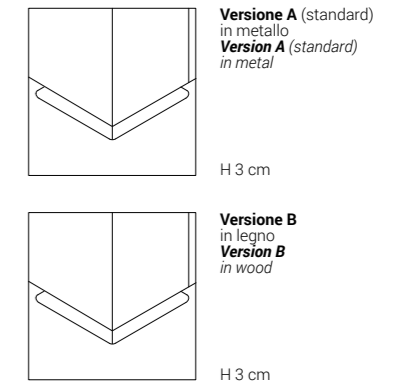

*Gli elementi componibili Gordon Move possono essere liberamente combinati con gli elementi Gordon per creare infinite composizioni*

*The different elements of Gordon Move can be combined with the modular elements of Gordon to create several and different compositions*

Movimento schienali  
Backrest mechanism



| Foot code | Shiny chrome metal<br>OPM1   | Brushed matt chrome metal<br>OPM2 | Matt brushed dark grey metal<br>OPM3 | RAL 9017 black painted metal<br>OPM6 | Classic bronze painted metal<br>OPM9 | Brushed copper metal<br>OPM12       | Brushed antique brass metal<br>OPM13 | Shiny black chrome metal<br>OPM14 | Brushed antique gold metal<br>OPM15 |                                 |
|-----------|------------------------------|-----------------------------------|--------------------------------------|--------------------------------------|--------------------------------------|-------------------------------------|--------------------------------------|-----------------------------------|-------------------------------------|---------------------------------|
| Version A | ●                            | ●                                 | ●                                    | ●                                    | ●                                    | ●                                   | ●                                    | ●                                 | ●                                   |                                 |
| Foot code | Cherry stained beech<br>OPF1 | Wengé stained beech<br>OPF2       | Walnut stained beech<br>OPF3         | Natural beech<br>OPF4                | Black stained beech<br>OPF5          | Cherry Milano stained beech<br>OPF6 | Tobacco stained beech<br>OPF8        | Grey taupe stained beech<br>OPF9  | Charcoal stained beech<br>OPF11     | Mahogany stained beech<br>OPF12 |
| Version B | ●                            | ●                                 | ●                                    | ●                                    | ●                                    | ●                                   | ●                                    | ●                                 | ●                                   | ●                               |

# Gordon

Design **Studio Marelli** 2014

Fusto in legno massello e legno multistrato con cinghie elastiche intrecciate. Imbottitura in poliuretano espanso rivestito in vellutino bianco. Cuscini di schienale in Piumafib, una speciale miscela ipoallergenica di vera piuma e fibra poliestere siliconata\*.

Cuscini di seduta costituiti da un inserto in poliuretano con densità di 30 Kg/m<sup>3</sup> ricoperto da un trapuntino di vera piuma imbottito a scomparti\*.

Completamente sfoderabile in tessuto, non sfoderabile in pelle e finta pelle.

Kit letto disponibile.

Disponibile anche nella versione con cuscini di seduta e schienale trapuntati

\* Manutenzione dei cuscini contenenti piuma:

I cuscini contenenti piuma tendono a deformarsi con l'utilizzo.

Per mantenerne la forma è necessario, anche dopo un breve utilizzo, battere e sprimacciare ripetutamente i cuscini. Non utilizzare mai battipanni o aspirapolvere.

A coloro che non desiderassero seguire queste indicazioni o che volessero un divano dall'aspetto meno vissuto, raccomandiamo di preferire dei cuscini in gomma.

Carcasse en bois massif et multiplis muni de bandes élastiques entrecroisées et finie de mousse polyuréthane couverte de dacron. Coussins de dossier en Piumafib, un mélange hypoallergénique spécial de véritable duvet et fibre polyester siliconisée\*.

Les coussins d'assise sont composés d'un noyau en mousse polyuréthane d'une densité de 30 kg/m<sup>3</sup> couvert de véritable duvet matelassé en compartiments\*.

Revêtement complètement déhoussable en tissu, fixe en cuir et cuir look.

Disponibile en canapé-lit.

Également disponible avec les coussins d'assise et de dossier matelassés.

\* Entretien de coussins en duvet: Coussins en duvet ont tendance à perdre leur forme dû à l'usage.

Pour en conserver la forme il est nécessaire, aussi après un usage court, de régulièrement battre les coussins. Ne jamais utiliser la tapette ou l'aspirateur. À ceux qui ne désirent pas suivre ces indications ou qui souhaitent un canapé qui ait l'air moins "usé", nous conseillons vivement de choisir des coussins en mousse polyuréthane.

Frame made of solid wood and multi-ply wood with interwoven elastic straps. The upholstery is made of polyurethane foam, covered with dacron. The back cushions are filled with Piumafib, a special hypoallergenic mixture of feathers and siliconised polyfibre\*.

The seat cushions are made of a foam insert with density of 30 Kg/m<sup>3</sup>, covered with a feather compartments quilt\*.

Fully removable fabric covers, fixed leather and artificial leather covers.

Sofa-bed is available.

Available also with quilted seat and back cushions.

\* Maintenance of feather cushions:

Cushions filled with feathers tend to change their shape with use.

In order to keep their shape it is necessary, even after short use, to plump up the cushions repeatedly. Never use carpet beater or vacuum cleaner.

We recommend to choose foam cushions to those who do not wish to follow these instructions or to have a "used look" sofa.

Romp in massief hout en multiplex, voorzien van door elkaar geweven elastische singels en bekleed met koudschuim afgewerkt met dacron. Rugkussens in Piumafib, een speciale hypoallergene mengeling van echt dons en gesiliconiseerde polyestervezel\*.

De zitkussens bestaan uit een kern in koudschuim met een densiteit van 30 kg/m<sup>3</sup> met daarbovenop een in vakken doorstikte laag echt dons\*.

Volledig afneembare bekleding in stof, vaste bekleding in leder en lederlook.

Ook verkrijgbaar als bedbank.

Ook verkrijgbaar met doorstikte zit- en rugkussens.

\* Onderhoud van kussens met dons vulling:

Kussens met dons vulling hebben de neiging door het gebruik hun vorm te verliezen.

Om hun vorm te behouden is het noodzakelijk, ook na kort gebruik, de kussens regelmatig op te kloppen. Nooit een mattenklopper of stofzuiger gebruiken.

Wie deze voorschriften niet wenst te volgen of een zitmeubel wenst dat er minder "slordig" uitziet, raden wij met aandrang aan voor kussens met koudschuim vulling te kiezen.

Das Gestell besteht aus Massiv- und Schichtholz, mit geflochtenen Gummigurten, gepolstert mit Polyurethanschaumstoff, mit Dacron bezogen. Rueckenkissen aus Piumafib, einer hypoallergischen speziellen Mischung aus echter Daune und silikonisierter Polyesterfaser\*.

Die Sitzkissen bestehen aus einem Schaumkern mit Dichte 30 Kg/m<sup>3</sup> mit einer gekammerten Daunenauf-lage\*.

Stoffbezüge alle abziehbar, Leder und Kunstleder festbezogen.

Als Bettsofa verfügbare.

Verfügbare auch mit abgesteppten Sitz- und Rueckenkissen.

\* Wartungsanleitungen fuer Daunen-kissen:

Die Kissen, die Daunen enthalten, neigen dazu, sich durch Gebrauch zu verformen.

Um die urspruengliche Form zu halten, ist es notwendig, auch nach kurzem Gebrauch, die Kissen wiederholt aufzuschueteln.

Keinen Ausklopper oder Staubsauger verwenden. Unseren Kunden, die diese Anweisungen nicht befolgen moechten, oder die kein Sofa mit solchem "gebrauchten" Aussehen haben moechten, empfehlen wir Polyurethan-Kissen.

Для производства каркаса используется массив дерева и многослойная фанера в сочетании с перекрещивающимися эластичными ремнями. Наполнение из полиуретана, обернутого в белый бархат. Наполнение подушек спинки выполнено из материала Piumafib – специальной, не вызывающей аллергии смеси из натурального пуха и полиэфирных силиконовых волокон\*. Подушки сиденья: стеганые по отсекам, наполнение из натурального пуха с вставками из полиуретана плотностью 30 кг/м<sup>3</sup> \*.

Полностью съемные чехлы из ткани, несъемные чехлы из кожи.

Исполнение дивана в версии со спальным местом: возможно Также возможно изготовление подушек сиденья и спинки с декоративной прострочкой

\* Эксплуатация подушек с пуховым наполнением: В процессе эксплуатации подушки с пуховым наполнением могут деформироваться, во избежание чего их необходимо слегка взбивать вручную даже после непродолжительного нахождения на диване. Использование в этих целях пылесоса или выбивалки для одежды категорически запрещено. Если клиент не планирует следовать данным инструкциям и хочет, чтобы подушки сиденья и спинки проминались по минимуму, посоветуйте выбрать наполнение только из полиуретана, полностью исключив натуральный пух.

# Leaf

Design **Studio Marelli** 2009

# marelli



Server **LEAF** 7LE101 cm 63,8x25x51h in metallo spazzolato oro antico.

*LEAF* server 7LE101 cm 63,8x25x51h in brushed antique gold metal.

Server **LEAF** 7LE101 cm 63,8x25x51h in metallo spazzolato cromo satinato.

*LEAF server 7LE101 cm 63,8x25x51h in brushed matt chrome metal.*



Server **LEAF** 7LE101 cm 63,8x25x51h in diverse finiture.

*LEAF server 7LE101 cm 63,8x25x51h in different finishes.*





Server **LEAF** 7LE101 cm 63,8x25x51h in metallo spazzolato oro antico.

*LEAF* server 7LE101 cm 63,8x25x51h in brushed antique gold metal.

# Leaf

Design **Studio Marelli** 2009

Tavolino in metallo, base spessore 10 mm, top spessore 5 mm.

Finiture metallo verniciato:

- RAL 9017 nero traffico
- RAL 9016 bianco traffico
- RAL 7044 grigio seta
- RAL 1019 beige grigiastro
- RAL 7006 grigio beige
- RAL 9006 alluminio brillante
- classic bronze
- golden beach
- gold pearl
- tutti gli altri colori RAL Classic

Finiture metallo cromato o spazzolato:

- cromo lucido
- spazzolato cromo satinato
- spazzolato canna di fucile
- spazzolato rame
- spazzolato ottone antico
- cromo nero lucido
- spazzolato oro antico

Table d'appoint en métal, épaisseur de la base 10 mm, épaisseur du plateau 5 mm

Finitions pour métal laqué:

- RAL 9017 noir signalisation
- RAL 9016 blanc signalisation
- RAL 7044 gris soie
- RAL 1019 beige gris
- RAL 7006 gris beige
- RAL 9006 aluminium blanc
- classic bronze
- golden beach
- gold pearl
- toutes les autres couleurs RAL Classic

Finitions pour métal chromé ou brossé:

- chromé brillant
- chromé mat brossé
- brossé canon de fusil
- brossé cuivre
- brossé laiton antique
- chromé noir brillant
- brossé or antique

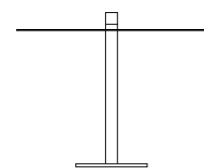
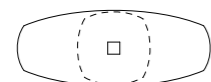

7LE101  
L64 P25 H51

Metal small table, base 10 mm thick, top 5 mm thick

Finishes for painted metal:

- RAL 9017 traffic black
- RAL 9016 traffic white
- RAL 7044 silk grey
- RAL 1019 grey beige
- RAL 7006 beige grey
- RAL 9006 white aluminium
- classic bronze
- golden beach
- gold pearl
- all the other RAL Classic colours

Finishes for chrome or brushed metal:

- shiny chrome
- brushed matt chrome
- brushed matt dark grey
- brushed copper
- brushed antique brass
- shiny black chrome
- brushed antique gold

Bijzettafeltje in metaal, dikte van de voetplaat 10 mm, bladdikte 4 mm

Afwerkingen voor gelakt metaal:

- RAL 9017 verkeerszwart
- RAL 9016 verkeerswit
- RAL 7044 zijdegrijs
- RAL 1019 grijsbeige
- RAL 7006 beigegrijs
- RAL 9006 blank aluminiumkleurig
- classic bronze
- golden beach
- gold pearl
- alle andere RAL Classic-kleuren

Afwerkingen voor verchromd of geborsteld metaal:

- glanschrom
- matchroom geborsteld
- canon de fusil geborsteld
- koper geborsteld
- antiek messing geborsteld
- glanschrom zwart
- antiek goud geborsteld

Metallkleintisch, Sockelstärke 10 mm, Plattenstärke 5 mm

Ausführungen für lackiertes Metall:

- RAL 9017 verkehrsschwarz
- RAL 9016 verkehrsweiß
- RAL 7044 seidengrau
- RAL 1019 grau beige
- RAL 7006 beigegrau
- RAL 9006 weissaluminium
- classic bronze
- golden beach
- gold pearl
- alle anderen RAL Classic-Farben

Ausführungen für verchromtes oder gebürstetes Metall:

- glänzend verchromt
- matt verchromt (gebürstet)
- dunkelgrau gebürstet
- Kupfer gebürstet
- Antik Messing gebürstet
- schwarz glänzend verchromt
- Antik Gold gebürstet

Столик металлический, толщина каркаса 10 мм, толщина столешницы 4 мм

Варианты отделки для окрашенного металла

- RAL 9017 дорожно - черный
- RAL 9016 дорожно - белый
- RAL 7044 шелково - серый
- RAL 1019 бежево - серый
- RAL 7006 серо - бежевый
- RAL 9006 бело - алюминиевый
- бронзовый классический
- золотой песок (golden beach)
- золотой жемчуг (golden pearl)
- любой цвет из палитры RAL Classic

Варианты отделки для хромированного металла или металла спазцолато

- хром глянцевый
- хром сатиновый спазцолато (см. примечание)
- темно-серый (canna di fucile) спазцолато
- латунь спазцолато
- состаренная медь спазцолато
- хром черный глянцевый
- золото состаренное спазцолато

Примечание: spazzolato - вид отделки поверхности, при котором она обрабатывается специальными щетками, в результате чего создается декоративный эффект неровности.

| Code  | Shiny chrome metal   | Brushed matt metal          | Brushed matt dark grey metal | RAL 9017 black painted metal | RAL 9016 white painted metal     | Metal painted in RAL Classic colors | Classic bronze painted metal      | Golden beach painted metal             | Gold pearl painted metal |
|-------|----------------------|-----------------------------|------------------------------|------------------------------|----------------------------------|-------------------------------------|-----------------------------------|--|--------------------------|
| Metal | ●                    | ●                           | ●                            | ●                            | ●                                | ●                                   | ●                                 | ●                                      | ●                        |
| Code  | Brushed copper metal | Brushed antique brass metal | Shiny black chrome metal     | Brushed antique gold metal   | RAL 7044 silk grey painted metal | RAL 1019 grey beige painted metal   | RAL 7006 beige grey painted metal | RAL 9006 white aluminium painted metal |                          |
| Metal | ●                    | ●                           | ●                            | ●                            | ●                                | ●                                   | ●                                 | ●                                      |                          |

# Loft

Design **Studio Marelli** 2013

**marelli**



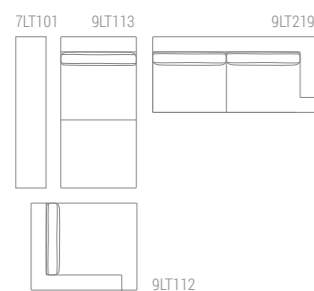

Composizione **LOFT100** cm 355x315 in tessuto cat. E art. San Mateo col. 3 con cuscini 9CU103 cm 40x40 e 9CU105 cm 50x50 nello stesso tessuto, base versione C e mobile in rovere tinto RAL 7037 grigio polvere, e cuscini con fascia 9VR102 cm 45x45 e senza fascia 9CU103 cm 40x40 in pelle cat. Super art. Dollaro col. 7110. Tavolino **TAB** 7TAB114 ø cm 125x36h con struttura in metallo cromo nero lucido, piano inferiore in vetro grigio retroverniciato cromo e piano superiore in marmo Calacatta oro lucido; tavolini **TWINS** 7TW114 cm 45x45x51h con base in rovere tinto antracite e top in marmo Calacatta oro lucido, 7TW101 ø cm 51x37h e 7TW102 ø cm 51x51h in rovere tinto antracite. Poltrona RIBOT 9RB101 cm 78x103x89h in tessuto cat. E art. San Mateo col. 17 con retro e fianchi in pelle cat. Super art. Dollaro col. 7110 e tavolino **TOM** 7TM102 ø cm 40x50h in tulipier tinto noce.

**LOFT100** composition cm 355x315 in fabric cat. E art. San Mateo col. 3 with cushions 9CU103 cm 40x40 and 9CU105 cm 50x50 in the same fabric, base version C and shelf in RAL 7037 grey painted oak and cushions with band 9VR102 cm 45x45 and without band 9CU103 cm 40x40 in leather cat. Super art. Dollaro col. 7110. **TAB** table 7TAB114 ø 125x36h with shiny black chrome metal structure, chrome back-painted grey glass lower top and shiny Calacatta gold marble upper top; **TWINS** coffee tables 7TW114 cm 45x45x51h with charcoal stained oak base and shiny Calacatta gold marble top, 7TW101 ø cm 51x37h and 7TW102 ø cm 51x51h in charcoal stained oak. RIBOT armchair 9RB101 cm 78x103x89h in fabric cat. E art. San Mateo col. 17 with back and sides in leather cat. Super art. Dollaro col. 7110 and **TOM** coffee table 7TM102 ø cm 40x50h in walnut stained tulipier.



Dettaglio di composizione **LOFT100** in tessuto cat. E art. San Mateo col. 3, tavolini **TWINS** 7TW101 ø cm 51x37h e 7TW102 ø cm 51x51h in rovere verniciato RAL 7001 grigio argento e server **LEAF** 7LE101 cm 64x25x51h in metallo spazzolato oro antico.

*Detail of **LOFT100** composition in fabric cat. E art. San Mateo col. 3, **TWINS** coffee tables 7TW101 ø cm 51x37h and 7TW102 ø cm 51x51h in RAL 7001 silver grey painted oak and **LEAF** server 7LE101 cm 64x25x51h in antique gold brushed metal.*



Composizione **LOFT 110** cm 305x330 con cuscini 9CU103 cm 40x40, 9CU106 cm 45x45 e 9CU105 cm 50x50 in pelle cat. Lusso art. Brevia col. 4203 con base versione A in metallo verniciato classic bronze. Server **LEAF** cm 63,8x25x51h in metallo spazzolato oro antico, tavolini TAB 7TAB116 cm 90x90x36h con struttura in

metallo spazzolato canna di fucile, piano inferiore in vetro bronzato retroverniciato cromo e piano superiore in marmo Emperador marrone lucido; libreria **FRAME** 7FR154 cm 130x40x155h con struttura in metallo verniciato RAL 7006 e piani in vetro retroverniciato RAL 7006.

**LOFT 110** composition cm 305x330 with cushions 9CU103 cm 40x40, 9CU106 cm 45x45 and 9CU105 cm 50x50 in leather cat. Lusso art. Brevia col. 4203 with base version A in classic bronze painted metal. **LEAF** server 63,8x25x51h in antique gold brushed metal, TAB tables 7TAB116 cm 90x90x36h

with brushed matt dark grey metal structure, chrome back-painted bronze glass lower top and shiny Emperador brown upper top; **FRAME** bookshelf 7FR154 cm 130x40x155h with RAL 7006 painted metal structure and RAL 7006 back-painted glass tops.

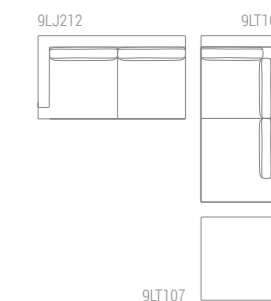

Composizione **LOFT 110** cm 305x330 con cuscini 9CU103 cm 40x40, 9CU106 cm 45x45 e 9CU105 cm 50x50 in pelle cat. Lusso art. Brevia col. 4203 con base versione A in metallo verniciato classic bronze. Server **LEAF** cm 63,8x25x51h in metallo spazzolato oro antico, tavolini TAB 7TAB116 cm 90x90x36h con struttura in metallo spazzolato canna di fucile, piano inferiore in vetro bronzato retroverniciato cromo e piano superiore in marmo Emperador marrone lucido; libreria **FRAME** 7FR154 cm 130x40x155h con struttura in metallo verniciato RAL 7006 e piani in vetro retroverniciato RAL 7006.

**LOFT 110** composition cm 305x330 with cushions 9CU103 cm 40x40, 9CU106 cm 45x45 and 9CU105 cm 50x50 in leather cat. Lusso art. Brevia col. 4203 with base version A in classic bronze painted metal. **LEAF** server 63,8x25x51h in antique gold brushed metal, **TAB** tables 7TAB116 cm 90x90x36h with brushed matt dark grey metal structure, chrome back-painted bronze glass lower top and shiny Emperador brown upper top; **FRAME** bookshelf 7FR154 cm 130x40x155h with RAL 7006 painted metal structure and RAL 7006 back-painted glass tops.

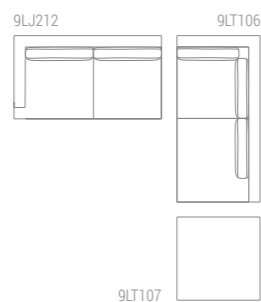



Divano **LOFT110** 9LJ204 cm 260x110x90h con cuscini 9CU103 cm 40x40 e 9CU105 cm 50x50 in pelle cat. Lusso art. Brevia col. 4203 con base versione A in metallo verniciato classic bronze.

***LOFT110** sofa 9LJ204 cm 260x110x90h with cushions 9CU103 cm 40x40 and 9CU105 cm 50x50 in leather cat. Lusso art. Brevia col. 4203 with base version A in classic bronze painted metal.*



Divano **LOFT110** 9LJ204 cm 260x110x90h e cuscini 9CU106 cm 45x45 in tessuto cat. E art. San Mateo col. 2 e cuscino 9CU105 cm 50x50 in pelle cat. Super art. Dollaro col. 7110. Server **FRAME** 7FR127 cm 55x27x51,5h con base in metallo cromato lucido e top in marmo nero Marquinia lucido. Tavolino **FRAME** 7FR105 ø cm 120x28h con base in metallo cromo nero lucido e top in vetro grigio retroverniciato cromo e

tavolino **BREAK** 7BR102 ø cm 60x36h con base in metallo cromo nero lucido e top in marmo nero Marquinia lucido. Poltrona e pouf **FLY** 9FY101 cm 78x88x108h e 9FY102 cm 65x50x40h in pelle cat. Super art. Dollaro col. 7070 e base in metallo verniciato classic bronze. Totem **FRAME** 7FR107 cm 40x40x155h con struttura in metallo verniciato nero e piani in vetro retroverniciato RAL 9017 nero.

**LOFT110** sofa 9LJ204 cm 260x110x90h and cushions 9CU106 cm 45x45 in fabric cat. E art. San Mateo col. 02 and cushion 9CU105 cm 50x50 in leather cat. Super art. Dollaro col. 7110. **FRAME** server 7FR127 cm 55x27x51,5h with shiny chrome metal base and shiny Marquinia black marble top. **FRAME** table 7FR105 ø cm 120x28h with shiny black chrome metal base and chrome back-painted grey glass

and **BREAK** coffee table 7BR102 ø cm 60x36h with shiny black chrome metal base and shiny Marquinia black marble top. **FLY** armchair and pouf 9FY101 cm 78x88x108h and 9FY102 cm 65x50x40h in leather cat. Super art. Dollaro col. 7070 and classic bronze painted metal base. **FRAME** totem 7FR107 cm 40x40x155h with black painted metal base and RAL 9017 black back-painted glass tops.



Divano **LOFT110** 9LJ204 cm 260x110x90h e cuscini 9CU106 cm 45x45 in tessuto cat. E art. San Mateo col. 2 e cuscino 9CU105 cm 45x45 in pelle cat. Super art. Dollaro col. 7110. Server **FRAME** 7FR127 cm 55x27x51,5h con base in metallo cromato lucido e top in marmo nero Marquinia lucido. Tavolino **FRAME** 7FR105 ø cm 120x28h con base in metallo cromo nero lucido e top in vetro grigio retroverniciato cromo e tavolino **BREAK** 7BR102 ø cm 60x36h con base in metallo cromo nero lucido e top in marmo nero Marquinia lucido. Poltrona e pouf **FLY** 9FY101 cm 78x88x108h e 9FY102 cm 65x50x40h in pelle cat. Super art. Dollaro col. 7070 e base in metallo verniciato classic bronze.

**LOFT110** sofa 9LJ204 cm 260x110x90h and cushions 9CU106 cm 45x45 in fabric cat. E art. San Mateo col. 02 and cushion 9CU105 cm 45x45 in leather cat. Super art. Dollaro col. 7110. **FRAME** server 7FR127 cm 55x27x51,5h with shiny chrome metal base and shiny Marquinia black marble top. **FRAME** table 7FR105 ø cm 120x28h with shiny black chrome metal base and chrome back-painted grey glass and **BREAK** coffee table 7BR102 ø cm 60x36h with shiny black chrome metal base and shiny Marquinia black marble top. **FLY** armchair and pouf 9FY101 cm 78x88x108h and 9FY102 cm 65x50x40h in leather cat. Super art. Dollaro col. 7070 and classic bronze painted metal base.



Poltrona e pouf **FLY** 9FY101 cm 78x88x108h e 9FY102 cm 65x50x40h in pelle cat. Super art. Dollaro col. 7070 e base in metallo verniciato classic bronze. Totem **FRAME** 7FR107 cm 40x40x155h con struttura in metallo verniciato nero e piani in vetro retroverniciato RAL 9017 nero.

**FLY** armchair and pouf 9FY101 cm 78x88x108h and 9FY102 cm 65x50x40h in leather cat. Super art. Dollaro col. 7070 and classic bronze painted metal base. **FRAME** totem 7FR107 cm 40x40x155h with black painted metal base and RAL 9017 black back-painted glass tops.



# Loft100

Design **Studio Marelli** 2013

Divani  
Sofas

Elementi componibili  
Modular elements

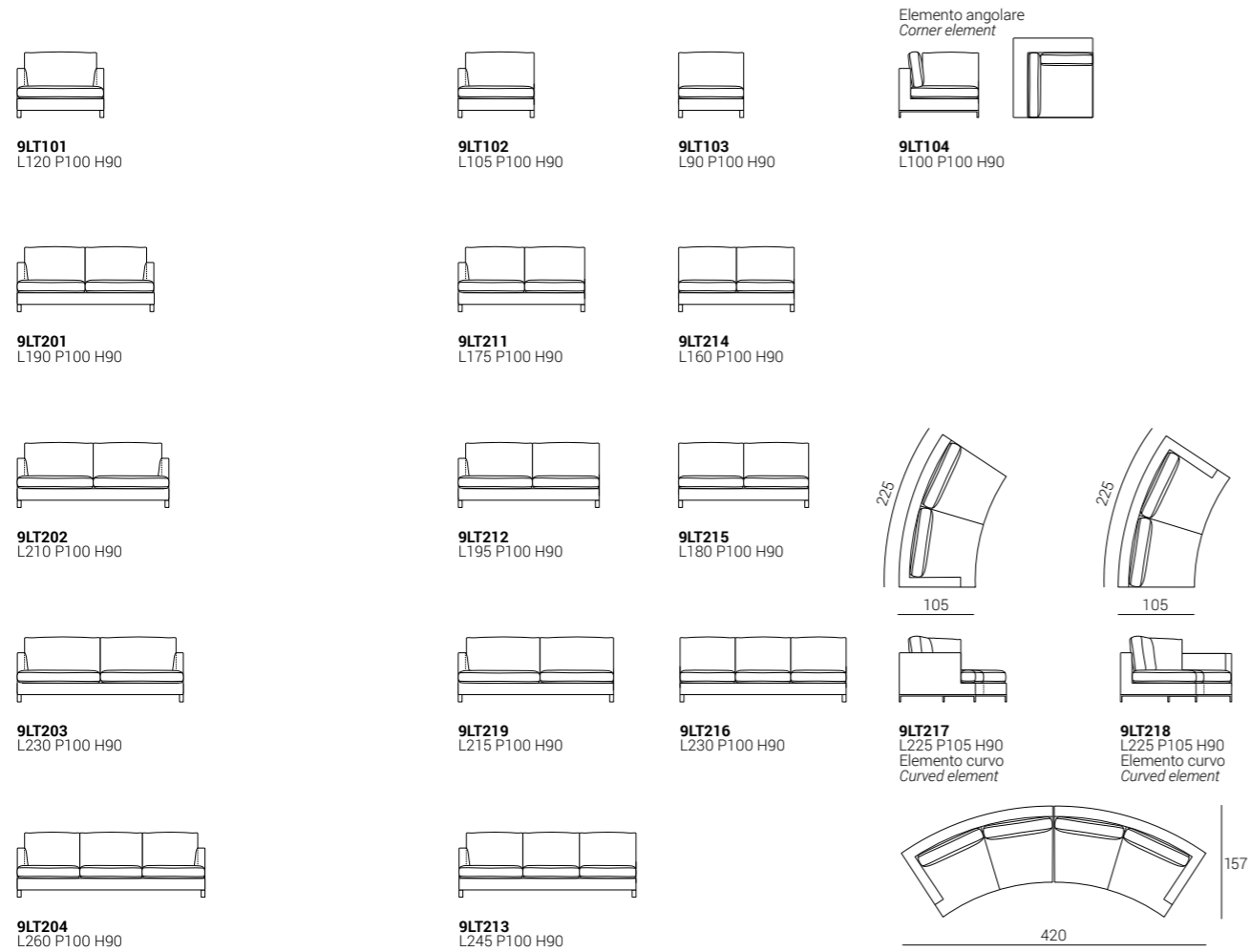

Dormeuse  
Longchair

Pouf e accessori  
Pouf and accessories

Piedini  
Feet

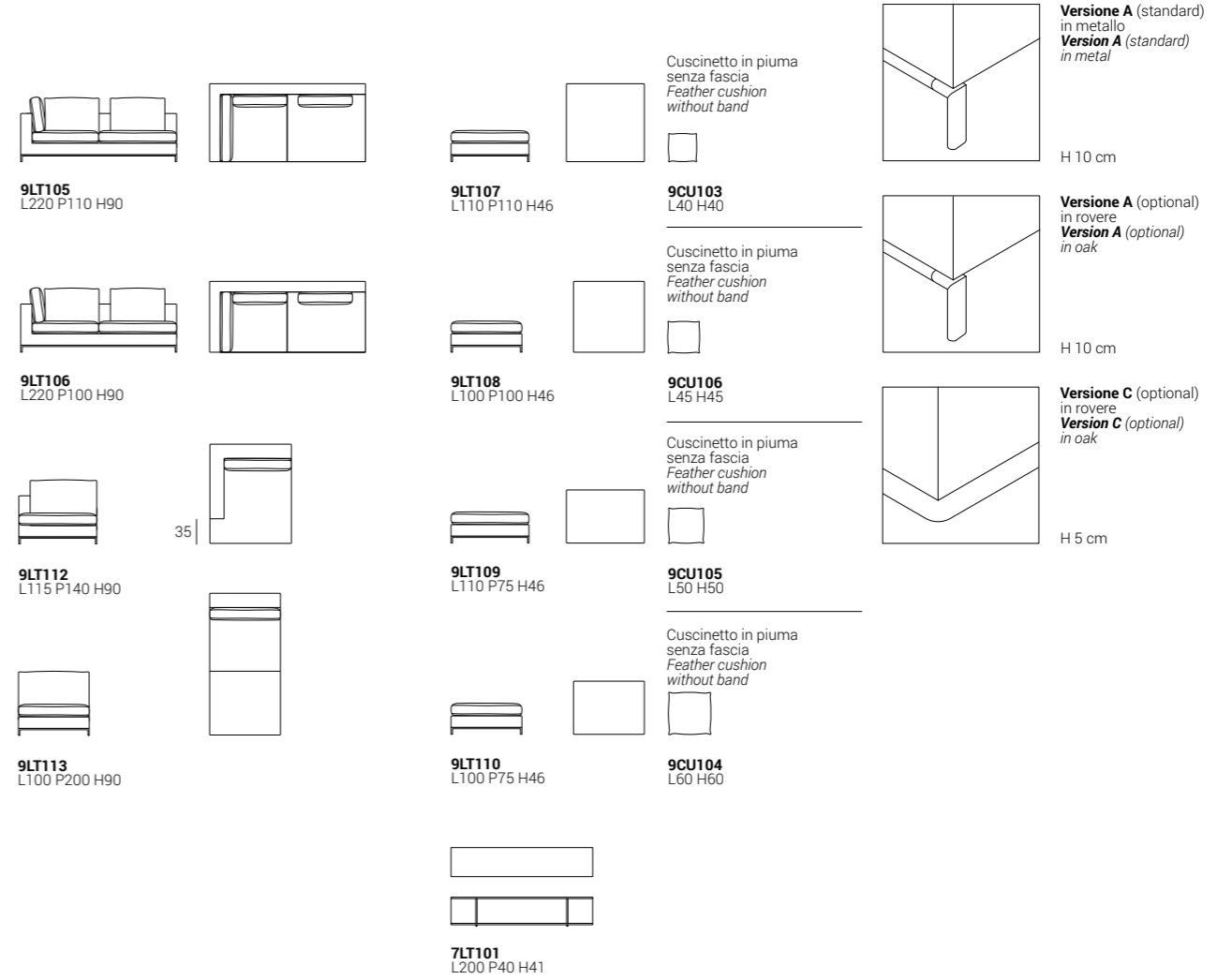

Le misure delle altezze si riferiscono al modello con base A standard  
The height sizes are referred to the model with standard base A

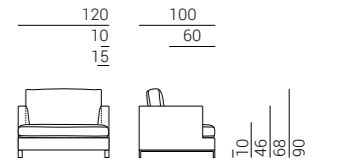

| Code               | Shiny chrome metal | Brushed matt chrome metal | Matt brushed dark grey metal | RAL 9017 black painted metal | Classic bronze painted metal | Brushed copper metal | Brushed antique brass metal | Shiny black chrome metal | Brushed antique gold metal |       |       |
|--------------------|--------------------|---------------------------|------------------------------|------------------------------|------------------------------|----------------------|-----------------------------|--------------------------|----------------------------|-------|-------|
| Version A          | OPM1               | OPM2                      | OPM3                         | OPM6                         | OPM9                         | OPM12                | OPM13                       | OPM14                    | OPM15                      |       |       |
| Version A optional | OPR1               | OPR2                      | OPR3                         | OPR4                         | OPR5                         | OPR6                 | OPR8                        | OPR9                     | OPR10                      | OPR11 | OPR12 |
| Version C + 7LT101 | OPR1               | OPR2                      | OPR3                         | OPR4                         | OPR5                         | OPR6                 | OPR8                        | OPR9                     | OPR10                      | OPR11 | OPR12 |



# Loft110

Design **Studio Marelli** 2013

**Divani Sofas**

**Elementi componibili Modular elements**

**9LJ101**  
L120 P110 H90

**9LJ102**  
L105 P110 H90

**9LJ103**  
L90 P110 H90

**9LJ104**  
L110 P110 H90

**9LJ201**  
L190 P110 H90

**9LJ211**  
L175 P110 H90

**9LJ214**  
L160 P110 H90

**9LJ202**  
L210 P110 H90

**9LJ212**  
L195 P110 H90

**9LJ215**  
L180 P110 H90

**9LJ203**  
L230 P110 H90

**9LJ219**  
L215 P110 H90

**9LJ216**  
L230 P110 H90

**9LJ204**  
L260 P110 H90

**9LJ213**  
L245 P110 H90

**Elemento angolare Corner element**

**9LT105**  
L220 P110 H90

**9LT106**  
L220 P100 H90

**9LT112**  
L115 P140 H90

**9LT113**  
L100 P200 H90

**9LT217**  
L225 P105 H90  
Elemento curvo Curved element

**9LT218**  
L225 P105 H90  
Elemento curvo Curved element

Dimensions: 225, 105, 157, 420

**Dormeuse Longchair**

**Pouf e accessori Pouf and accessories**

**Piedini Feet**

**9LT105**  
L220 P110 H90

**9LT106**  
L220 P100 H90

**9LT112**  
L115 P140 H90

**9LT113**  
L100 P200 H90

**9LT107**  
L110 P110 H46

**9LT108**  
L100 P100 H46

**9LT109**  
L110 P75 H46

**9LT110**  
L100 P75 H46

**9CU103**  
L40 H40

**9CU106**  
L45 H45

**9CU105**  
L50 H50

**9CU104**  
L60 H60

**7LT101**  
L200 P40 H41

Cuscinetto in piuma senza fascia Feather cushion without band

**Versione A (standard) in metallo**  
**Version A (standard) in metal**

H 10 cm

**Versione A (optional) in rovere**  
**Version A (optional) in oak**

H 10 cm

**Versione C (optional) in rovere**  
**Version C (optional) in oak**

H 5 cm

Le misure delle altezze si riferiscono al modello con base A standard  
The height sizes are referred to the model with standard base A

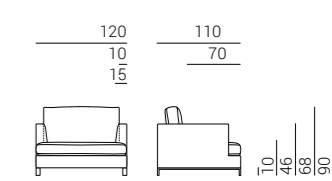

|                    |                    |                           |                              |                              |                              |                           |                             |                          |                            |                      |                      |
|--------------------|--------------------|---------------------------|------------------------------|------------------------------|------------------------------|---------------------------|-----------------------------|--------------------------|----------------------------|----------------------|----------------------|
|                    | Shiny chrome metal | Brushed matt chrome metal | Matt brushed dark grey metal | RAL 9017 black painted metal | Classic bronze painted metal | Brushed copper metal      | Brushed antique brass metal | Shiny black chrome metal | Brushed antique gold metal |                      |                      |
| <b>Code</b>        | <b>OPM1</b>        | <b>OPM2</b>               | <b>OPM3</b>                  | <b>OPM6</b>                  | <b>OPM9</b>                  | <b>OPM12</b>              | <b>OPM13</b>                | <b>OPM14</b>             | <b>OPM15</b>               |                      |                      |
| Version A          | ●                  | ●                         | ●                            | ●                            | ●                            | ●                         | ●                           | ●                        | ●                          |                      |                      |
|                    | Cherry stained oak | Wengé stained oak         | Walnut stained oak           | Natural oak                  | Black stained oak            | Cherry Milano stained oak | Tobacco stained oak         | Grey taupe stained oak   | Whitened oak               | Charcoal stained oak | Mahogany stained oak |
| <b>Code</b>        | <b>OPR1</b>        | <b>OPR2</b>               | <b>OPR3</b>                  | <b>OPR4</b>                  | <b>OPR5</b>                  | <b>OPR6</b>               | <b>OPR8</b>                 | <b>OPR9</b>              | <b>OPR10</b>               | <b>OPR11</b>         | <b>OPR12</b>         |
| Version A optional | ●                  | ●                         | ●                            | ●                            | ●                            | ●                         | ●                           | ●                        | ●                          | ●                    | ●                    |
|                    | Cherry stained oak | Wengé stained oak         | Walnut stained oak           | Natural oak                  | Black stained oak            | Cherry Milano stained oak | Tobacco stained oak         | Grey taupe stained oak   | Whitened oak               | Charcoal stained oak | Mahogany stained oak |
| <b>Code</b>        | <b>OPR1</b>        | <b>OPR2</b>               | <b>OPR3</b>                  | <b>OPR4</b>                  | <b>OPR5</b>                  | <b>OPR6</b>               | <b>OPR8</b>                 | <b>OPR9</b>              | <b>OPR10</b>               | <b>OPR11</b>         | <b>OPR12</b>         |
| Version C + 7LT101 | ●                  | ●                         | ●                            | ●                            | ●                            | ●                         | ●                           | ●                        | ●                          | ●                    | ●                    |

# Loft

Design **Studio Marelli** 2013

Fusto in legno massello e legno multistrato con cinghie elastiche intrecciate. Imbottitura in poliuretano espanso rivestito in vellutino bianco. Cuscini di schienale in Piumafib, una speciale miscela ipoallergenica di vera piuma e fibra poliestere siliconata\*. Cuscini di seduta costituiti da un inserto in poliuretano con densità di 30 Kg/m<sup>3</sup> ricoperto da un trapuntino di vera piuma imbottito a scomparti\*. Completamente sfoderabile in tessuto, non sfoderabile in pelle e finta pelle.

Kit letto non disponibile.

Disponibile con profondità di seduta 100/110 cm

\*Manutenzione dei cuscini contenenti piuma:

I cuscini contenenti piuma tendono a deformarsi con l'utilizzo. Per mantenerne la forma è necessario, anche dopo un breve utilizzo, battere e sprimacciare ripetutamente i cuscini. Non utilizzare mai battipanni o aspirapolvere. A coloro che non desiderassero seguire queste indicazioni o che volessero un divano dall'aspetto meno vissuto, raccomandiamo di preferire dei cuscini in gomma.

Carcasse en bois massif et multiplis muni de bandes élastiques entrecroisées et finie de mousse polyuréthane couverte de dacron. Coussins de dossier en Piumafib, un mélange hypoallergénique spécial de véritable duvet et fibre polyester siliconisée\*. Les coussins d'assise sont composés d'un noyau en mousse polyuréthane d'une densité de 30 kg/m<sup>3</sup> couvert de véritable duvet broché en compartiments\*. Revêtement complètement déhoussable en tissu, fixe en cuir et cuir look.

Pas disponible en canapé-lit.

Profondeurs d'assise disponibles: cm 100/110

\*Entretien de coussins en duvet:

Coussins en duvet ont tendance à perdre leur forme dû à l'usage. Pour en conserver la forme il est nécessaire, aussi après un usage court, de régulièrement battre les coussins. Ne jamais utiliser la tapette ou l'aspirateur. À ceux qui ne désirent pas suivre ces indications ou qui souhaitent un canapé qui ait l'air moins "usé", nous conseillons vivement de choisir des coussins en mousse polyuréthane.

Frame made of solid wood and multi-ply wood with interwoven elastic straps. The upholstery is made of polyurethane foam, covered with dacron. The back cushions are filled with Piumafib, a special hypoallergenic mixture of feathers and siliconised polyfibre\*. The seat cushions are made of a foam insert with density of 30 Kg/m<sup>3</sup>, covered with a feather compartments quilt\*. Fully removable fabric covers, fixed leather and artificial leather covers. Sofa-bed is not available.

Available seat depths: 100/110 cm

\*Maintenance of feather cushions:

Cushions filled with feathers tend to change their shape with use. In order to keep their shape it is necessary, even after a short use, to plump up the cushions repeatedly. Never use carpet beater or vacuum cleaner. We recommend to choose foam cushions to those who do not wish to follow these instructions or to have a "used look" sofa.

Romp in massief hout en multiplex, voorzien van door elkaar geweve elastische singels en bekleed met koudschuim afgewerkt met dacron. Rugkussens in Piumafib, een speciale hypoallergene mengeling van echt dons en gesiliconiseerde polyestervezel\*. De zitkussens bestaan uit een kern in koudschuim met een densiteit van 30 kg/m<sup>3</sup> met daarbovenop een in vakken doorstikte laag echt dons\*. Volledig afneembare bekleding in stof, vaste bekleding in leder en lederlook.

Niet verkrijgbaar als bedbank.

Verkrijgbaar in de dieptes 100/110 cm

\*Onderhoud van kussens met donsruiling:

Kussens met donsruiling hebben de neiging door het gebruik hun vorm te verliezen. Om hun vorm te behouden is het noodzakelijk, ook na kort gebruik, de kussens regelmatig op te kloppen. Nooit een mattenklopper of stofzuiger gebruiken. Wie deze voorschriften niet wenst te volgen of een zitmeubel wenst dat er minder "slordig" uitziet, raden wij met aandrang aan voor kussens met koudschuimvulling te kiezen.

Das Gestell besteht aus Massiv- und Schichtholz, mit geflochtenen Gummigurten, gepolstert mit Polyurethanschaumstoff, mit Dacron bezogen. Rueckenkissen aus Piumafib, einer hypoallergischen speziellen Mischung aus echter Daune und silikonisierter Polyesterfaser\*. Die Sitzkissen bestehen aus einem Schaumkern mit Dichte 30 Kg/m<sup>3</sup> mit einer gekammerten Daunenaufgabe\*. Stoffbezüge alle abziehbar, Leder und Kunstleder festbezogen. Als Bettsofa nicht verfügbar.

Lieferbare Sitztiefen: 100/110 cm

Wartungsanleitungen fuer Daunenkissen:

Die Kissen, die Daunen enthalten, neigen dazu, sich durch Gebrauch zu verformen. Um die urspruengliche Form zu halten, ist es notwendig, auch nach kurzem Gebrauch, die Kissen wiederholt aufzuschueteln. Keinen Ausklopper oder Staubsauger verwenden. Unseren Kunden, die diese Anweisungen nicht befolgen moechten, oder die kein Sofa mit solchem "gebrauchten" Aussehen haben moechten, empfehlen wir Polyurethan-Kissen.

Для производства каркаса используется массив дерева и многослойная фанера в сочетании с перекрещивающимися эластичными ремнями. Наполнение из полиуретана, обернутого в белый бархат. Наполнение подушек спинки выполнено из материала Piumafib – специальной, не вызывающей аллергию смеси из натурального пуха и полиэфирных силиконовых волокон\*. Подушки сиденья: стеганные по отсекам, наполнение из натурального пуха с вставками из полиуретана плотностью 30 кг/м<sup>3</sup> \*. Полностью съемные чехлы из ткани, несъемные чехлы из кожи.

Вариант со спальным местом не предусмотрен.

Возможные варианты по глубине: 100/110 см

\*Эксплуатация подушек с пуховым наполнением:

В процессе эксплуатации подушки с пуховым наполнением могут деформироваться, во избежание чего их необходимо слегка взбивать вручную даже после непродолжительного нахождения на диване. Использование в этих целях пылесоса или выбивалки для одежды категорически запрещено. Если клиент не планирует следовать данным инструкциям и хочет, чтобы подушки сиденья и спинки проминались по минимуму, посоветуйте выбрать наполнение только из полиуретана, полностью исключив натуральный пух.

# Matheus

Design **Studio Marelli** 2015**marelli**

Divano **MATHEUS** cm 320x100x62h con cuscini con fascia cm 50x50 e 60x60 lisci e trapuntati e poltroncine **FRED SMALL** 9FS301 in pelle cat. Extra art. New Jersey col. Taupe. Base del divano e piedini delle poltroncine in metallo verniciato classic bronze. Tavolini **TAB** 7TAB116 cm 90x90x36h con struttura in metallo spazzolato canna di fucile, piano inferiore in vetro bronzato retroverniciato cromo e piano superiore in marmo Emperador marrone lucido.

**MATHEUS** sofa cm 320x100x62h with cushions with band cm 50x50 and 60x60 with and without quilting and **FRED SMALL** armchairs 9FS301 in leather cat. Extra art. New Jersey col. Taupe. Sofa base and armchairs feet in classic bronze painted metal. **TAB** tables 7TAB116 cm 90x90x36h with brushed matt dark grey metal structure, chrome back-painted bronze glass lower top and shiny Emperador brown upper top.

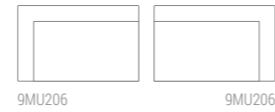

Composizione **MATHEUS** cm 320x300 con cuscini con fascia 9MU101 cm 50x50 e 9MU102 cm 60x60 in tessuto cat. E art. Fauna col. 443 e cuscini con fascia 9MU102 cm 60x60 in tessuto art. Fauna col. 166 con base in metallo cromo nero lucido. Consolle **FRAME** 7FR129 cm 160x40x70h

con struttura in metallo verniciato RAL 9017 nero, piano superiore in marmo Calacatta oro lucido e piano inferiore in vetro grigio retroverniciato cromo. Tavolini **FRAME** 7FR125 cm 100x100x28h con base in metallo cromo nero lucido e top in marmo Calacatta oro lucido.

**MATHEUS** composition cm 320x300 with cushions with band 9MU101 cm 50x50 and 9MU102 cm 60x60 in fabric cat. E art. Fauna col. 443 and cushions with band 9MU101 cm 50x50 in fabric cat. G art. Fauna col. 166 with shiny black chrome metal base.

**FRAME** consolle 7FR129 cm 160x40x70h with RAL 9017 black painted metal structure, shiny Calacatta gold marble top and chrome back-painted grey glass. **FRAME** coffee tables 7FR125 cm 100x100x28h with shiny black chrome base and shiny Calacatta gold marble top.

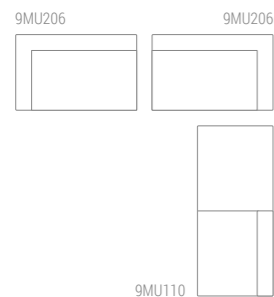

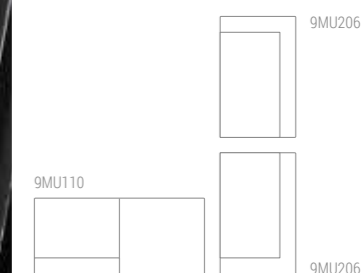

Composizione **MATHEUS** cm 320x300 con cuscini con fascia 9MU101 cm 50x50 e 9MU102 cm 60x60 in tessuto cat. E art. Fauna col. 443 e cuscini con fascia 9MU102 cm 60x60 in tessuto art. Fauna col. 166 con base in metallo cromo nero lucido. Consolle **FRAME** 7FR129 cm 160x40x70h con struttura in metallo verniciato RAL 9017 nero, piano superiore in marmo Calacatta oro lucido e piano inferiore in vetro grigio retroverniciato cromo. Tavolini **FRAME** 7FR125 cm 100x100x28h con base in metallo cromo nero lucido e top in marmo Calacatta oro lucido; tavolino **CLIP** 7CL103 ø cm 40x50h in metallo cromo nero lucido.

**MATHEUS** composition cm 320x300 with cushions with band 9MU101 cm 50x50 and 9MU102 cm 60x60 in fabric cat. G art. Fauna col. 443 and cushions with band 9MU101 cm 50x50 in fabric cat. G art. Fauna col. 166 with shiny black chrome metal base.

**FRAME** consolle 7FR129 cm 160x40x70h with RAL 9017 black painted metal structure, shiny Calacatta gold marble top and chrome back-painted grey glass. **FRAME** coffee tables 7FR125 cm 100x100x28h with shiny black chrome base and shiny Calacatta gold marble top; **CLIP** coffee table 7CL103 ø cm 40x50h in shiny black chrome metal.

Composizione **MATHEUS** cm 300x360 in tessuto cat. E art. Catria col. 11 con cuscini con fascia 9MU101 cm 50x50 e 9MU102 cm 60x60 nello stesso tessuto e cuscini trapuntati 9MU103 cm 50x50 con fascia e 9CUT104 cm 60x60 a saponetta in tessuto cat. F art. Lario col. 2012.  
Tavolo **TAB** 7TAB114 ø cm 125x36h con

struttura in metallo cromo nero lucido, piano inferiore in vetro grigio retroverniciato cromo e piano superiore in marmo Calacatta oro lucido. Pouf **ZAC** trapuntato 4ZAC102 cm 70x70x40h in tessuto cat. F art. Lario col. 2012 e tavolino **TWINS** 7TW114 cm 45x45x51h con base in rovere tinto antracite e top in marmo Calacatta oro lucido.

**MATHEUS** composition cm 300x360 in fabric cat. E art. Catria col. 11 with cushions with band 9MU101 cm 50x50 and 9MU102 cm 60x60 in the same fabric and quilted cushions 9MU103 cm 50x50 with band and 9CUT104 cm 60x60 without band in fabric cat. F art. Lario col. 2012.  
**TAB** table 7TAB114 ø 125x36h with shiny

black chrome metal structure, chrome back-painted grey glass lower top and shiny Calacatta gold marble upper top. **ZAC** quilted pouf 4ZAC102 cm 70x70x40h in fabric cat. F art. Lario col. 2012 and **TWINS** coffee table 7TW114 cm 45x45x51h with charcoal stained oak base and shiny Calacatta gold marble top.

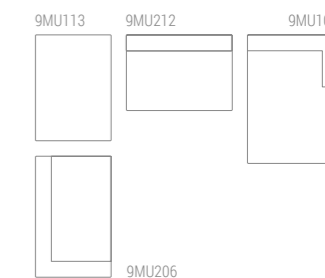

Composizione **MATHEUS** cm 300x200 con cuscini con fascia 9MU101 cm 50x50 e 9MU102 cm 60x60 in tessuto cat. E art. San Mateo col. 17 e cuscino con fascia 9VR101 cm 45x45 e senza fascia 9CU106 cm 45x45 in pelle cat. Super art. Dollaro col. 7110. Tavolini **STONE** 7ST110 cm 95x95x27h

con base in rovere tinto antracite e top in marmo Calacatta oro lucido e 7ST112 cm 120x45x27h con base in rovere tinto wengè e top in marmo Calacatta oro lucido. Tavolino **CIRCLE** 7CR111 ø cm 60x40h con base in metallo cromo nero lucido e top in vetro grigio retroverniciato cromo.

**MATHEUS** composition cm 300x200 with cushions with band 9MU101 cm 50x50 and 9MU102 cm 60x60 in fabric cat. E art. San Mateo col. 17 and cushion with band 9VR101 cm 45x45 and without band 9CU106 cm 45x45 in leather cat. Super art. Dollaro col. 7110. **STONE** tables 7ST110 cm 95x95x27h

with charcoal stained oak base and shiny Calacatta gold marble top and 7ST112 cm 120x45x27h with wengè stained oak base and shiny Calacatta gold marble top. **CIRCLE** coffee table 7CR111 ø cm 60x40h with shiny black chrome base and chrome back-painted grey glass.

9MU208

9MU105

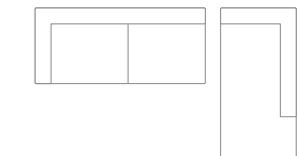

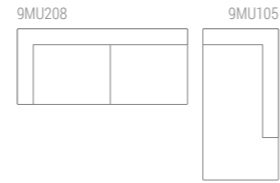

Composizione **MATHEUS** cm 300x200 con cuscini con fascia 9MU101 cm 50x50 e 9MU102 cm 60x60 in tessuto cat. E art. San Mateo col. 17 e cuscino con fascia 9VR101 cm 45x45 e senza fascia 9CU106 cm 45x45 in pelle cat. Super art. Dollaro col. 7110. Tavolini **TWINS** 7TW113 cm 45x45x37h e 7TW114 cm 45x45x51h con base in rovere tinto antracite e top in marmo Calacatta oro lucido.

**MATHEUS** composition cm 300x200 with cushions with band 9MU101 cm 50x50 and 9MU102 cm 60x60 in fabric cat. E art. San Mateo col. 17 and cushion with band 9VR101 cm 45x45 and without band 9CU106 cm 45x45 in leather cat. Super art. Dollaro col. 7110. **TWINS** coffee tables 7TW113 cm 45x45x37h and 7TW114 cm 45x45x51h with charcoal stained oak base and shiny Calacatta gold marble top.





Divano **MATHEUS** 9MU203 cm 220x100x62h con cuscini con fascia 9MU101 cm 50x50 e 9MU102 cm 60x60 in tessuto cat. E art. Fauna col. 166.

Poltrona **RIBOT** 9RB101 cm 78x103x89h in tessuto cat. E art. San Mateo col. 17 con retro e fianchi in pelle cat. Super art. Dollaro col. 7110. Tavolini **STONE** 7ST110 cm 95x95x27h con base in rovere

tinto antracite e top in marmo Perfetto brown opaco. Tavolini **TWINS** 7TW113 cm 45x45x37h e 7TW114 cm 45x45x51h con base in rovere tinto antracite e top in marmo Perfetto Brown opaco. Totem **FRAME** 7FR107 cm 40x40x155h con struttura in metallo verniciato nero e piani in vetro retroverniciato RAL 9017 nero.

**MATHEUS** sofa 9MU203 cm 220x100x62h with cushions with band 9MU101 cm 50x50 and 9MU102 cm 60x60 in fabric cat. E Art. Fauna col. 166.

**RIBOT** armchair 9RB101 cm 78x103x89h in fabric cat. E art. San Mateo col. 17 with back and sides in leather cat. Super art. Dollaro col. 7110. **STONE** tables 7ST110 cm 95x95x27h

with charcoal stained oak base and matt Perfetto brown marble top. **TWINS** tables 7TW113 cm 45x45x37h and 7TW114 cm 45x45x51h with charcoal stained oak base and matt Perfetto brown marble top. **FRAME** totem 7FR107 cm 40x40x155h with black painted metal base and RAL 9017 black back-painted glass tops.





Divano **MATHEUS** 9MU203 cm 220x100x62h con cuscini con fascia 9MU101 cm 50x50 e 9MU102 cm 60x60 in tessuto cat. E Art. Fauna col. 166

Tavolini **STONE** 7ST110 cm 95x95x27h con base in rovere tinto antracite e top in marmo Perfetto brown opaco. Tavolini **TWINS** 7TW113 cm 45x45x37h e 7TW104 ø cm 51x51h con base in rovere tinto antracite e top in marmo Perfetto Brown opaco.

***MATHEUS** sofa 9MU203 cm 220x100x62h with cushions with band 9MU101 cm 50x50 and 9MU102 cm 60x60 in fabric cat. E Art. Fauna col. 166*

***STONE** tables 7ST110 cm 95x95x27h with charcoal stained oak base and matt Perfetto brown marble top. **TWINS** tables 7TW113 cm 45x45x37h and 7TW104 cm 51x51h with charcoal stained oak base and matt Perfetto brown marble top.*

# Matheus

Design **Studio Marelli** 2015

Divani  
Sofas

Elementi componibili  
Modular elements

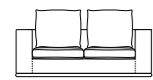

**9MU201**  
L180 P100 H88

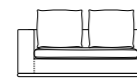

**9MU206**  
L160 P100 H88

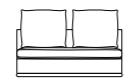

**9MU212**  
L140 P100 H88

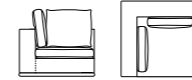

**9MU216**  
L100 P100 H88

Elemento angolare  
Corner element



**9MU202**  
L200 P100 H88



**9MU207**  
L180 P100 H88

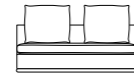

**9MU213**  
L160 P100 H88



**9MU101**  
L50 P50

Cuscino per schienale  
in piuma con fascia  
Feather back cushion  
with band

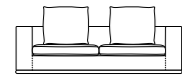

**9MU203**  
L220 P100 H88

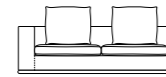

**9MU208**  
L200 P100 H88

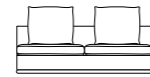

**9MU214**  
L180 P100 H88



**9MU102**  
L60 P60

Cuscino per schienale  
in piuma con fascia  
Feather back cushion  
with band

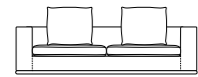

**9MU204**  
L240 P100 H88

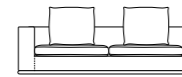

**9MU209**  
L220 P100 H88

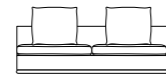

**9MU215**  
L200 P100 H88



**9MU103**  
L50 P50

Cuscino per schienale trapuntato  
in piuma con fascia  
Quilted feather back cushion  
with band

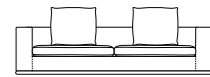

**9MU205**  
L260 P100 H88

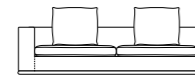

**9MU210**  
L240 P100 H88



**9MU104**  
L60 P60

Cuscino per schienale trapuntato  
in piuma con fascia  
Quilted feather back cushion  
with band

Poggia cuscino di schienale  
Backrest cushion support



**9MU116**  
L72 H60

Dormeuse  
Longchair

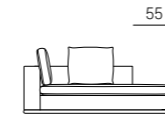

**9MU105**  
L200 P100 H88

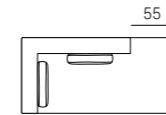

**9MU109**  
L220 P100 H88

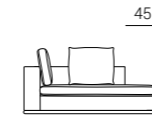

**9MU106**  
L180 P100 H88

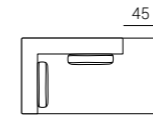

**9MU110**  
L200 P100 H88

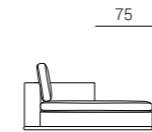

**9MU107**  
L170 P120 H88

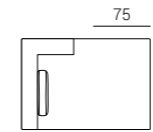

**9MU111**  
L180 P100 H88

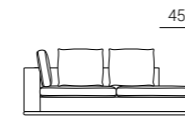

**9MU108**  
L225 P100 H88

Pouf e accessori  
Pouf and accessories



**9MU112**  
L160 P100 H38



**9MU113**  
L140 P100 H38



**9MU114**  
L100 P100 H38



**9MU115**  
L80 P80 H38

Cuscino in piuma  
senza fascia  
Feather back cushion  
without band



**9CU106**  
L45 P45

Cuscino in piuma  
trapuntato senza fascia  
Quilted Feather cushion  
without band



**9CU106**  
L45 P45

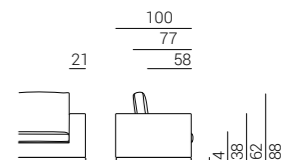

| Code      | Shiny chrome metal | Brushed matt chrome metal | Matt brushed dark grey metal | RAL 9017 black painted metal | Classic bronze painted metal | Brushed copper metal | Brushed antique brass metal | Shiny black chrome metal | Brushed antique gold metal |
|-----------|--------------------|---------------------------|------------------------------|------------------------------|------------------------------|----------------------|-----------------------------|--------------------------|----------------------------|
| Version A | ●                  | ●                         | ●                            | ●                            | ●                            | ●                    | ●                           | ●                        | ●                          |

# Matheus

Design **Studio Marelli** 2015

Fusto in legno massello e legno multistrato con cinghie elastiche intrecciate. Imbottitura in poliuretano espanso rivestito in vellutino bianco. Cuscini di schienale in Piumafib, una speciale miscela ipoallergenica di vera piuma e fibra poliestere siliconata\*. Cuscini di seduta costituiti da un inserto in poliuretano con densità di 30 Kg/m<sup>3</sup> ricoperto da un trapuntino di vera piuma imbottito a scomparti\*. Completamente sfoderabile in tessuto, non sfoderabile in pelle e finta pelle.

Kit letto non disponibile.

\*Manutenzione dei cuscini contenenti piuma:

I cuscini contenenti piuma tendono a deformarsi con l'utilizzo. Per mantenerne la forma è necessario, anche dopo un breve utilizzo, battere e sprimacciare ripetutamente i cuscini. Non utilizzare mai battipanni o aspirapolvere. A coloro che non desiderassero seguire queste indicazioni o che volessero un divano dall'aspetto meno vissuto, raccomandiamo di preferire dei cuscini in gomma.

Carcasse en bois massif et multiplis muni de bandes élastiques entrecroisées et finie de mousse polyuréthane couverte de dacron. Coussins de dossier en Piumafib, un mélange hypoallergénique spécial de véritable duvet et fibre polyester siliconisée\*.

Les coussins d'assise sont composés d'un noyau en mousse polyuréthane d'une densité de 30 kg/m<sup>3</sup> couvert de véritable duvet broché en compartiments\*. Revêtement complètement déhoussable en tissu, fixe en cuir et cuir look.

Pas disponible en canapé-lit.

\*Entretien de coussins en duvet:

Coussins en duvet ont tendance à perdre leur forme dû à l'usage. Pour en conserver la forme il est nécessaire, aussi après un usage court, de régulièrement battre les coussins. Ne jamais utiliser la tapette ou l'aspirateur. À ceux qui ne désirent pas suivre ces indications ou qui souhaitent un canapé qui ait l'air moins "usé", nous conseillons vivement de choisir des coussins en mousse polyuréthane.

Frame made of solid wood and multi-ply wood with interwoven elastic straps. The upholstery is made of polyurethane foam, covered with dacron. The back cushions are filled with Piumafib, a special hypoallergenic mixture of feathers and siliconised polyfibre\*. The seat cushions are made of a foam insert with density of 30 Kg/m<sup>3</sup>, covered with a feather compartments quilt\*. Fully removable fabric covers, fixed leather and artificial leather covers. Sofa-bed is not available.

\*Maintenance of feather cushions:

Cushions filled with feathers tend to change their shape with use. In order to keep their shape it is necessary, even after a short use, to plump up the cushions repeatedly. Never use carpet beater or vacuum cleaner. We recommend to choose foam cushions to those who do not wish to follow these instructions or to have a "used look" sofa.

Romp in massief hout en multiplex, voorzien van door elkaar geweve elastische singels en bekleed met koudschuim afgewerkt met dacron. Rugkussens in Piumafib, een speciale hypoallergene mengeling van echt dons en gesiliconiseerde polyestervezel\*. De zitkussens bestaan uit een kern in koudschuim met een densiteit van 30 kg/m<sup>3</sup> met daarbovenop een in vakken doorstikte laag echt dons\*. Volledig afneembare bekleding in stof, vaste bekleding in leder en lederlook.

Niet verkrijgbaar als bedbank.

\*Onderhoud van kussens met donsuvulling:

Kussens met donsuvulling hebben de neiging door het gebruik hun vorm te verliezen. Om hun vorm te behouden is het noodzakelijk, ook na kort gebruik, de kussens regelmatig op te kloppen. Nooit een mattenklopper of stofzuiger gebruiken. Wie deze voorschriften niet wenst te volgen of een zitmeubel wenst dat er minder "slordig" uitziet, raden wij met aandrang aan voor kussens met koudschuimvulling te kiezen.

Das Gestell besteht aus Massiv- und Schichtholz, mit geflochtenen Gummigurten, gepolstert mit Polyurethanschaumstoff, mit Dacron bezogen. Rueckenkissen aus Piumafib, einer hypoallergischen speziellen Mischung aus echter Daune und silikonisierter Polyesterfaser\*. Die Sitzkissen bestehen aus einem Schaumkern mit Dichte 30 Kg/m<sup>3</sup> mit einer gekammerten Daunenaufgabe\*. Stoffbezüge alle abziehbar, Leder und Kunstleder festbezogen. Als Bettsofa nicht verfügbar.

Wartungsanleitungen fuer Daunenkissen:

Die Kissen, die Daunen enthalten, neigen dazu, sich durch Gebrauch zu verformen. Um die ursprüngliche Form zu halten, ist es notwendig, auch nach kurzem Gebrauch, die Kissen wiederholt aufzuschütteln. Keinen Ausklopfer oder Staubsauger verwenden. Unseren Kunden, die diese Anweisungen nicht befolgen moechten, oder die kein Sofa mit solchem "gebrauchten" Aussehen haben moechten, empfehlen wir Polyurethan-Kissen.

Для производства каркаса используется массив дерева и многослойная фанера в сочетании с перекрещивающимися эластичными ремнями. Наполнение из полиуретана, обернутого в белый бархат. Наполнение подушек спинки выполнено из материала Piumafib – специальной, не вызывающей аллергию смеси из натурального пуха и полиэфирных силиконовых волокон\*. Подушки сиденья: стеганые по отсекам, наполнение из натурального пуха с вставками из полиуретана плотностью 30 кг/м<sup>3</sup> \*.

Полностью съемные чехлы из ткани, несъемные чехлы из кожи.

Вариант со спальным местом не предусмотрен.

\*Эксплуатация подушек с пуховым наполнением: В процессе эксплуатации подушки с пуховым наполнением могут деформироваться, во избежание чего их необходимо слегка взбивать вручную даже после непродолжительного нахождения на диване. Использование в этих целях пылесоса или выбивалки для одежды категорически запрещено. Если клиент не планирует следовать данным инструкциям и хочет, чтобы подушки сиденья и спинки проминались по минимуму, посоветуйте выбрать наполнение только из полиуретана, полностью исключив натуральный пух.

# Mike

Design **Studio Marelli** 2015**marelli**

Tavolo **MIKE** 7MK102 cm 240x100x73h con gambe in rovere verniciato RAL 7037 grigio e top in marmo Calacatta oro lucido e poltroncine girevoli **PIVOT** 7PIV101 cm 55,5x54x80h con struttura in rovere verniciato RAL 7037 grigio e seduta e schienale in tessuto cat. E art. Fauna col. 443.

**MIKE** table 7MK102 cm 240x100x73h with oak legs painted in colour RAL 7037 grey and shiny Calacatta gold marble top and **PIVOT** swivel armchairs 7PIV101 cm 55,5x54x80h with oak structure painted in colour RAL 7037 grey and seat and back in fabric cat. E art. Fauna col. 443.



Tavolo **MIKE** 7MK102 cm 240x100x73h con gambe in rovere verniciato RAL 7037 grigio e top in marmo Calacatta oro lucido e poltroncine girevoli **PIVOT** 7PIV101 cm 55,5x54x80h con struttura in rovere verniciato RAL 7037 grigio e seduta e schienale in tessuto cat. E art. Fauna col. 443.

***MIKE** table 7MK102 cm 240x100x73h with oak legs painted in colour RAL 7037 grey and shiny Calacatta gold marble top and **PIVOT** swivel armchairs 7PIV101 cm 55,5x54x80h with oak structure painted in colour RAL 7037 grey and seat and back in fabric cat. E art. Fauna col. 443.*





Sedie alte **NICOLE** 9NK101 cm 53x56x91h in pelle cat. Super art. Panama col. 5270 con base in rovere tinto antracite e tavolo **MIKE** 7MK102 cm 240x100x73h con gambe in rovere tinto antracite e piano in marmo Emperador marrone lucido.

**NICOLE** chairs with high back 9NK101 cm 53x56x91h in leather cat. Super art. Panama col. 5270 with charcoal stained oak base and **MIKE** dining table 7MK102 cm 240x100x73h with charcoal stained oak base and shiny Emperador brown marble top.



Sedie basse **NICOLE** 9NK102 cm 53x56x74h in pelle cat. Super art. Panama col. 5270 con base in rovere tinto antracite e tavolo **MIKE** 7MK102 cm 240x100x73h con gambe in rovere tinto antracite e piano in marmo Emperador marrone lucido.

***NICOLE** chairs with low back 9NK102 cm 53x56x74h in leather cat. Super art. Panama col. 5270 with charcoal stained oak base and **MIKE** dining table 7MK102 cm 240x100x73h with charcoal stained oak base and shiny Emperador brown marble top.*





Sedie alte **NICOLE** 9NK101 cm 53x56x91h in pelle cat. Super art. Panama col. 5270 con base in rovere tinto antracite e tavolo **MIKE** 7MK102 cm 240x100x73h con gambe in rovere tinto antracite e piano in marmo Emperador marrone lucido.

**NICOLE** chairs with high back 9NK101 cm 53x56x91h in leather cat. Super art. Panama col. 5270 with charcoal stained oak base and **MIKE** dining table 7MK102 cm 240x100x73h with charcoal stained oak base and shiny Emperador brown marble top.

# Mike

Design **Studio Marelli** 2015

Telaio in metallo verniciato nero o bianco. Gambe in tubo di metallo rivestito in rovere massello. Sottopiano portante in HPL, su cui viene fissato il top.

- Top:
- rovere europeo impiallacciato, spessore 20 mm, con bordo in MDF
  - marmo, spessore 20 mm, disponibile nelle seguenti finiture, lucido oppure opaco:
  - bianco Carrara
  - nero Marquinia
  - marrone Emperador
  - Perfetto brown
  - Calacatta oro
  - Black and Gold

Piètement en métal laqué noir ou blanc. Pieds en tube de métal revêtu de chêne massif. Sousstructure portante en HPL, sur laquelle est fixé le plateau.

- Plateau:
- placage de chêne européen, épaisseur 20 mm, avec bord en MDF
  - marbre, épaisseur 20 mm, disponible dans les finitions suivantes, brillant ou mat:
  - blanc Carrara
  - noir Marquinia
  - brun Emperador
  - brun Perfetto
  - or Calacatta
  - Black & Gold

Table frame in black or white painted metal. Metal tube legs covered with solid oak wood. Underlying supporting surface in HPL, on which the top is fixed.

- Top:
- European oak veneer, 20 mm thick, with MDF edges
  - marble, 20 mm thick, available in the following finishes, shiny or matt:
  - Carrara white
  - Marquinia black
  - Emperador brown
  - Perfetto brown
  - Calacatta gold
  - Black and Gold

Onderstel in zwart of wit gelakt metaal. Poten in buismetaal bekleed met massief eiken. Dragend onderblad in HPL, waarop het blad bevestigd wordt.

- Blad:
- Europees eiken fineer, dikte 20 mm, met boord in MDF
  - marmer, dikte 20 mm, verkrijgbaar in de volgende afwerkingen, glanzend of mat:
  - Carrara White
  - Marquinia Black
  - Emperador Brown
  - Perfetto Brown
  - Calacatta Gold
  - Black & Gold

Das Tischgestell besteht aus Metall, schwarz oder weiss lackiert. Metallgestell mit Eiche Echtholz furniert. Die Tischplatte ist mit einer HPL-Platte unterlegt.

- Platte:
- europäische Eiche furniert, Plattenstärke 20 mm, Kanten aus MDF.
  - Marmor, Plattenstärke 20 mm, in den folgenden Ausführungen, glänzend oder matt, lieferbar:
  - Carrara weiss
  - Marquinia schwarz
  - Emperador braun
  - Perfetto braun
  - Calacatta gold
  - Black and Gold

Металлический каркас, окрашенный в черный либо белый цвет. Ножки из металлической трубы в сочетании с массивом дуба.

- Столешница крепится на несущую подложку из ламината высокого давления (HPL, "High Pressure Laminate")
- Столешница, толщина 20мм
- массив европейского дуба, фанерованный шпоном, кромка МДФ
  - мрамор, глянцевый либо матовый, варианты:
  - bianco Carrara
  - nero Marquinia
  - marrone Emperador
  - perfetto brown
  - Calacatta oro
  - Black and Gold

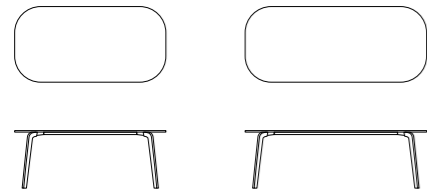

**7MK101**  
Top in marmo / Marble top  
L200 P100 H73

**7MK102**  
Top in marmo / Marble top  
L240 P100 H73

| Code | White Carrara marble | Black Marquinia marble | Brown Emperador marble | Perfetto brown marble | Calacatta gold marble | Black and Gold marble     |                     |                        |                |                      |                      |
|------|----------------------|------------------------|------------------------|-----------------------|-----------------------|---------------------------|---------------------|------------------------|----------------|----------------------|----------------------|
| Top  | ● <b>OPP1</b>        | ● <b>OPP2</b>          | ● <b>OPP3</b>          | ● <b>OPP6</b>         | ● <b>OPP7</b>         | ● <b>OPP9</b>             |                     |                        |                |                      |                      |
| Code | Cherry stained oak   | Wengé stained oak      | Walnut stained oak     | Natural oak           | Black stained oak     | Cherry Milano stained oak | Tobacco stained oak | Grey taupe stained oak | Whitened oak   | Charcoal stained oak | Mahogany stained oak |
| Base | ● <b>OPR1</b>        | ● <b>OPR2</b>          | ● <b>OPR3</b>          | ● <b>OPR4</b>         | ● <b>OPR5</b>         | ● <b>OPR6</b>             | ● <b>OPR8</b>       | ● <b>OPR9</b>          | ● <b>OPR10</b> | ● <b>OPR11</b>       | ● <b>OPR12</b>       |

# New York

Design **Studio Marelli** 2015

# marelli

Divano **NEW YORK** 9NY205 cm 260x102x70h con cuscini a saponetta 9CU104 cm 60x60x e 9CU106 cm 45x45 in tessuto cat. F art. Lario col. 54, basamento in metallo spazzolato cromo satinato. Server **FRAME** 7FR127 cm 55x27x51,5h con base in metallo spazzolato cromo satinato e top in marmo nero Marquinia lucido e tavolino **STONE** 7ST110 cm 95x95x27h con struttura in rovere tinto antracite e top in marmo nero Marquinia lucido.

**NEW YORK** sofa 9NY205 cm 260x102x70h with cushions 9CU104 cm 60x60 and 9CU106 cm 45x45 in fabric cat. F art. Lario col. 54, brushed matt chrome metal base. **FRAME** server 7FR127 cm 55x27x51,5h with brushed matt chrome metal base and shiny Marquinia black marble top and **STONE** coffee table 7ST110 cm 95x95x27h with charcoal stained oak base and shiny black Marquinia marble top.



Divano **NEW YORK** 9NY205 cm 260x102x70h con cuscini di schienale con fascia 9NY101 cm 70x50 e 9NY103 cm 50x50 e pouf 9NY214 cm 95x95x41h in pelle cat. Extra art. New Jersey col. Nero con basamento in metallo spazzolato cromo satinato. Tavolini **CLIP** 7CL103 ø cm 40x50h in metallo spazzolato ottone antico e **BREAK** 7BR102 ø cm 60x36h con base in metallo spazzolato ottone antico e top in marmo Emperador marrone lucido.

**NEW YORK** sofa 9NY205 cm 260x102x70h with back cushions with band 9NY101 cm 70x50 and 9NY103 cm 50x50 and pouf 9NY214 cm 95x95x41h in leather cat. Extra art. New Jersey col. Black with brushed matt chrome metal base. **CLIP** coffee table 7CL103 ø cm 40x50h in brushed antique brass metal and **BREAK** coffee table 7BR102 ø cm 60x36h with brushed antique brass metal base and shiny Emperador brown marble top.





Dettaglio di divano **NEW YORK** 9NY205 cm  
260x102x70h con cuscino di schienale con  
fascia 9NY101 cm 70x50 in pelle cat. Extra  
art. New Jersey col. Nero con basamento in  
metallo spazzolato cromo satinato.

*Detail of **NEW YORK** sofa 9NY205 cm  
260x102x70h with back cushion with band  
9NY101 cm 70x50 in leather cat. Extra art. New  
Jersey col. Black with brushed matt chrome  
metal base.*

Composizione **NEW YORK** cm 330x220 in tessuto cat. E art. San Mateo col. 02 con basamento in metallo spazzolato cromo satinato e cuscini di schienale con fascia 9NY101 cm 70x50 e cuscini a saponetta 9CU106 cm 45x45 nello stesso tessuto e cuscino a saponetta 9CU106 cm 45x45, cuscino con fascia 9NY102 cm 60x50 e cuscino con fascia 9NY103 cm 50x50 in pelle cat. Extra art. New Jersey col. Taupe. Tavolino **CLIP** 7CL102 ø cm 40x40h in metallo spazzolato oro antico, tavolino **FRAME** 7FR121 ø cm 100x28h con base

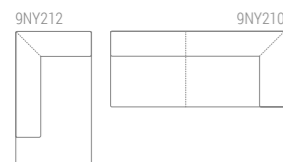

in metallo cromo lucido e top in marmo Perfetto brown opaco e tavolino **CIRCLE** 7CR111 ø cm 60x40h con base in metallo spazzolato cromo satinato e top in marmo Perfetto brown opaco. Totem **FRAME** 7FR107 cm 40x40x155h con struttura in metallo verniciato nero e piani in vetro retroverniciato RAL 9017 nero. Consolle **FRAME** 7FR130 cm 200x40x70h con struttura in metallo verniciato nero, piano superiore in marmo Calacatta oro lucido e piano inferiore in vetro grigio retroverniciato cromo.

**NEW YORK** composition cm 330x220 in fabric cat. E art. San Mateo col. 02 with brushed matt chrome metal base and back cushions with band 9NY101 cm 70x50 and cushions without band 9CU106 cm 45x45 in the same fabric and cushion without band 9CU106 cm 45x45, cushion with band 9NY102 cm 60x50 and cushion with band 9NY103 cm 50x50 in leather cat. Extra art. New Jersey col. Taupe. **CLIP** coffee table 7CL102 ø cm 40x40h in brushed antique gold metal, **FRAME** table

7FR121 ø cm 100x28h with shiny chrome metal base and matt Perfetto brown marble top and **CIRCLE** coffee table 7CR111 ø cm 60x40h with brushed matt chrome metal base and matt Perfetto brown marble top. **FRAME** totem 7FR107 cm 40x40x155h with black painted metal structure and RAL 9017 black back-painted glass tops. **FRAME** console 7FR130 cm 200x40x70h with black painted metal structure, shiny Calacatta gold upper top and chrome back-painted grey glass lower top.



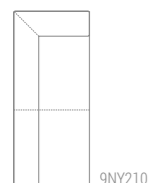

9NY210



9NY212

Composizione **NEW YORK** cm 330x220 in tessuto cat. E art. San Mateo col. 02 con basamento in metallo spazzolato cromo satinato e cuscini di schienale con fascia 9NY101 cm 70x50 e cuscini a saponetta 9CU106 cm 45x45 nello stesso tessuto e cuscino a saponetta 9CU106 cm 45x45, cuscino con fascia 9NY102 cm 60x50 e cuscino con fascia 9NY103 cm 50x50 in pelle cat. Extra art. New Jersey col. Taupe. Tavolino **CLIP** 7CL102 ø cm 40x40h in metallo spazzolato oro antico, tavolino **FRAME** 7FR121 ø cm 100x28h con base in metallo cromo lucido e top in marmo Perfetto brown opaco. Totem **FRAME** 7FR107 cm 40x40x155h con struttura in metallo verniciato nero e piani in vetro retroverniciato RAL 9017 nero. Console **FRAME** 7FR130 cm 200x40x70h con struttura in metallo verniciato nero, piano superiore in marmo Calacatta oro lucido e piano inferiore in vetro grigio retroverniciato cromo.

**NEW YORK** composition cm 330x220 in fabric cat. E art. San Mateo col. 02 with brushed matt chrome metal base and back cushions with band 9NY101 cm 70x50 and cushions without band 9CU106 cm 45x45 in the same fabric and cushion without band 9CU106 cm 45x45, cushion with band 9NY102 cm 60x50 and cushion with band 9NY103 cm 50x50 in leather cat. Extra art. New Jersey col. Taupe. **CLIP** coffee table 7CL102 ø cm 40x40h in brushed antique gold metal, **FRAME** table 7FR121 ø cm 100x28h with shiny chrome metal base and matt Perfetto brown marble top. **FRAME** totem 7FR107 cm 40x40x155h with black painted metal structure and RAL 9017 black back-painted glass tops. **FRAME** console 7FR130 cm 200x40x70h with black painted metal structure, shiny Calacatta gold top upper top and chrome back-painted grey glass lower top.



Divano **NEW YORK** 9NY305 cm 260x102x70h con cuscini di schienale con fascia 9NY101 cm 70x50 e a saponetta 9CU104 cm 60x60 e poltrona 9NY301 cm 130x102x70h in tessuto cat. E art. San Mateo col. 02. Tavolino **CLIP** 7CL102 ø cm 40x40h in metallo spazzolato

oro antico, tavolino **FRAME** 7FR121 ø cm 100x28h con base in metallo cromo lucido e top in marmo Perfetto brown opaco e **BREAK** 7BR103 ø cm 80x27h con base in metallo spazzolato ottone antico e top in marmo Calacatta oro lucido.

**NEW YORK** sofa 9NY305 cm 260x102x70h with back cushions with band 9NY101 cm 70x50 and without band 9CU104 cm 60x60 and armchair 9NY301 cm 130x102x70h in fabric cat. E art. San Mateo col. 02. **CLIP** coffee table 7CL102 ø cm 40x40h in brushed

antique gold metal, **FRAME** table 7FR121 ø cm 100x28h with shiny chrome metal base and matt Perfetto brown marble top and **BREAK** coffee table 7BR103 ø cm 80x27h with brushed antique brass metal base and shiny Calacatta gold marble top.





Poltrona **NEW YORK** 9NY301 cm 130x102x70h con cuscino con fascia 9NY103 cm 50x50 in tessuto cat. E art. San Mateo col. 02 e base in metallo spazzolato cromo satinato. Tavolini **CLIP** 7CL102 ø cm 40x40h e 7CL103 ø cm 40x50h in metallo spazzolato oro antico e tavolino **FRAME** 7FR121 ø cm 100x28h con base in metallo cromo lucido e top in marmo Perfetto brown opaco.

**NEW YORK** armchair 9NY301 cm 130x102x70h with cushion with band 9NY103 cm 50x50 in fabric cat. E art. San Mateo col. 02 and brushed matt chrome metal base. **CLIP** coffee tables 7CL102 ø cm 40x40h and 7CL103 ø cm 40x50h in antique gold brushed metal and **FRAME** table 7FR121 ø cm 100x28h with shiny chrome metal base and matt Perfetto brown marble top.



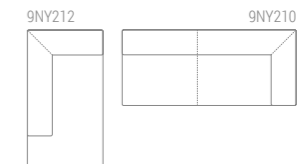

Composizione **NEW YORK** cm 330x220 in tessuto cat. E art. San Mateo col. 02 con basamento in metallo spazzolato cromo satinato e cuscini di schienale con fascia 9NY101 cm 70x50 e cuscini a saponetta 9CU106 cm 45x45 nello stesso tessuto e cuscino a saponetta 9CU106 cm 45x45, cuscino con fascia 9NY102 cm 60x50 e cuscino con fascia 9NY103 cm 50x50 in pelle cat. Extra art. New Jersey col. Taupe. Tavolino **FRAME** 7FR121 ø cm 100x28h con base in metallo cromo lucido e top in marmo Perfetto brown opaco e tavolino **CIRCLE** 7CR111 ø cm 60x40h con base in metallo spazzolato cromo satinato.

**NEW YORK** composition cm 330x220 in fabric cat. E art. San Mateo col. 02 with brushed matt chrome metal base and back cushions with band 9NY101 cm 70x50 and cushions without band 9CU106 cm 45x45 in the same fabric and cushion without band 9CU106 cm 45x45, cushion with band 9NY102 cm 60x50 and cushion with band 9NY103 cm 50x50 in leather cat. Extra art. New Jersey col. Taupe. **FRAME** table 7FR121 ø cm 100x28h with shiny chrome metal base and matt Perfetto brown marble top and **CIRCLE** coffee table 7CR111 ø cm 60x40h with brushed matt chrome metal base.

# New York

Design **Studio Marelli** 2015

Divani  
Sofas

Elementi componibili  
Modular elements

Pouf e accessori  
Pouf and accessories

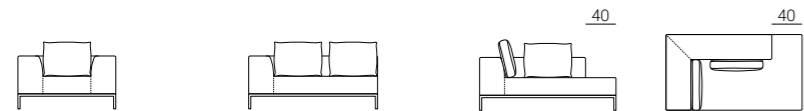

**9NY201** L130 P100 H85  
**9NY209** L170 P100 H85  
**9NY212** L180 P100 H85

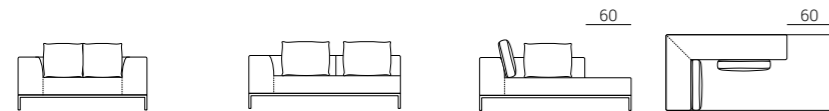

**9NY202** L170 P100 H85  
**9NY210** L200 P100 H85  
**9NY213** L220 P100 H85



**9NY203** L200 P100 H85  
**9NY211** L230 P100 H85

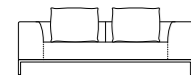

**9NY204** L230 P100 H85

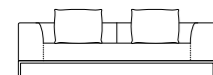

**9NY205** L260 P100 H85



**9NY214** L95 P95 H41

Cuscino di schienale  
in piuma con fascia  
Feather back cushion  
with band



**9NY101** L70 P50

Cuscino di schienale  
in piuma con fascia  
Feather back cushion  
with band



**9NY102** L60 P50

Cuscino in piuma  
con fascia  
Feather back cushion  
with band



**9NY103** L50 P50

Cuscino in piuma  
senza fascia  
Feather back cushion  
without band



**9CU104** L60 P60

Cuscino in piuma  
senza fascia  
Feather back cushion  
without band



**9CU106** L45 P45

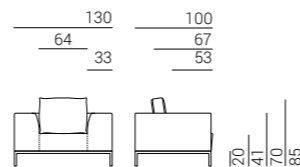

|      |                    |                           |                              |                              |                              |                      |                             |                          |                            |
|------|--------------------|---------------------------|------------------------------|------------------------------|------------------------------|----------------------|-----------------------------|--------------------------|----------------------------|
| Code | Shiny chrome metal | Brushed matt chrome metal | Matt brushed dark grey metal | RAL 9017 black painted metal | Classic bronze painted metal | Brushed copper metal | Brushed antique brass metal | Shiny black chrome metal | Brushed antique gold metal |
| Base | OPM1               | OPM2                      | OPM3                         | OPM6                         | OPM9                         | OPM12                | OPM13                       | OPM14                    | OPM15                      |

Divani  
Sofas

Elementi componibili  
Modular elements

Pouf e accessori  
Pouf and accessories



**9NY301** L130 P100 H85  
**9NY309** L170 P100 H85  
**9NY312** L180 P100 H85



**9NY302** L170 P100 H85  
**9NY310** L200 P100 H85  
**9NY313** L220 P100 H85



**9NY303** L200 P100 H85  
**9NY311** L230 P100 H85

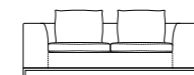

**9NY304** L230 P100 H85

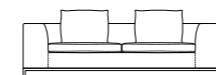

**9NY305** L260 P100 H85



**9NY314** L95 P95 H41

Cuscino di schienale  
in piuma con fascia  
Feather back cushion  
with band



**9NY101** L70 P50

Cuscino di schienale  
in piuma con fascia  
Feather back cushion  
with band



**9NY102** L60 P50

Cuscino in piuma  
con fascia  
Feather back cushion  
with band



**9NY103** L50 P50

Cuscino in piuma  
senza fascia  
Feather back cushion  
without band



**9CU104** L60 P60

Cuscino in piuma  
senza fascia  
Feather back cushion  
without band



**9CU106** L45 P45

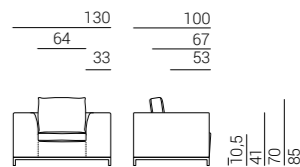

|      |                    |                           |                              |                              |                              |                      |                             |                          |                            |
|------|--------------------|---------------------------|------------------------------|------------------------------|------------------------------|----------------------|-----------------------------|--------------------------|----------------------------|
| Code | Shiny chrome metal | Brushed matt chrome metal | Matt brushed dark grey metal | RAL 9017 black painted metal | Classic bronze painted metal | Brushed copper metal | Brushed antique brass metal | Shiny black chrome metal | Brushed antique gold metal |
| Base | OPM1               | OPM2                      | OPM3                         | OPM6                         | OPM9                         | OPM12                | OPM13                       | OPM14                    | OPM15                      |

# New York

Design **Studio Marelli** 2015

Fusto in legno massello e legno multistrato con cinghie elastiche intrecciate.

Imbottitura in poliuretano espanso con densità 40 Kg/m<sup>3</sup> rivestito in dacron.

Seduta e schienale in poliuretano espanso con densità di 30 Kg/m<sup>3</sup>, rivestito in dacron.

Cuscini di schienale in piuma.

Rivestimento non sfoderabile né in tessuto, né in pelle e finta pelle.

Kit letto non disponibile.

Carcasse en bois massif et multiplis muni de bandes élastiques entrecroisées et finie de mousse de polyuréthane d'une densité de 40 kg/m<sup>3</sup> couverte de dacron.

Assise et dossier en mousse de polyuréthane d'une densité de 30 kg/m<sup>3</sup>, couverte de dacron.

Coussins de dossier en plumes.

Le revêtement est toujours fixe.

Pas disponible en canapé-lit.

Frame made of solid wood and multi-ply wood with interwoven elastic straps, upholstered with polyurethane foam with density of 40 Kg/m<sup>3</sup>, covered with dacron.

Seat and back in polyurethane foam with density of 30 Kg/m<sup>3</sup>, covered with dacron.

Feather back cushions.

Fixed fabric, leather and artificial leather covers.

Sofa-bed is not available.

Romp in massief hout en multiplex, voorzien van door elkaar geweven elastische singels en bekleed met koudschuim met een densiteit van 40 kg/m<sup>3</sup> afgewerkt met dacron.

Rug en zit in koudschuim met een densiteit van 30 kg/m<sup>3</sup>, afgedekt met dacron.

Rugkussens in dons.

De bekleding is altijd vast.

Niet verkrijgbaar als bedbank.

Das Gestell besteht aus Massiv- und Schichtholz, mit geflochtenen Gummigurten, gepolstert mit Polyurethan-Schaumstoff 40 Kg/m<sup>3</sup>, mit Dacron ummantelt.

Sitz und Rücken bestehen aus Polyurethan-Schaumstoff 30 Kg/m<sup>3</sup>, mit Dacron ummantelt. Rückenissen in Daune.

New York ist immer festbezogen.

Als Bettsofa nicht verfügbar.

Для производства каркаса используется массив дерева и многослойная фанера в сочетании с перекрещивающимися эластичными ремнями. Наполнение из вспененного полиуретана плотностью 40 кг/м<sup>3</sup>, обернутого в дакрон. Наполнение спинки и сиденья: вспененный пенополиуретан плотностью 30 кг/м<sup>3</sup>, обернутый в дакрон. Наполнение подушек спинки: пух. Чехля несъемные независимо от варианта обивки (ткань, кожа, искусственная кожа) Версия со спальным местом не предусмотрена

# Nicole

Design **Studio Marelli** 2015

# marelli

Sedie alte **NICOLE** 9NK101 cm 53x56x91h in pelle cat. Super art. Panama col. 5270 con base in rovere tinto antracite e tavolo **MIKE** 7MK102 cm 240x100x73h con gambe in rovere tinto antracite e piano in marmo Emperador marrone lucido.

***NICOLE** chairs with high back 9NK101 cm 53x56x91h in leather cat. Super art. Panama col. 5270 with charcoal stained oak base and **MIKE** dining table 7MK102 cm 240x100x73h with charcoal stained oak base and shiny Emperador brown marble top.*



Sedie alte **NICOLE** 9NK101 cm 53x56x91h in pelle cat. Super art. Panama col. 5270 con base in rovere tinto antracite e tavolo **MIKE** 7MK102 cm 240x100x73h con gambe in rovere tinto antracite e piano in marmo Emperador marrone lucido.

**NICOLE** chairs with high back 9NK101 cm 53x56x91h in leather cat. Super art. Panama col. 5270 with charcoal stained oak base and **MIKE** dining table 7MK102 cm 240x100x73h with charcoal stained oak base and shiny Emperador brown marble top.



Sedia alta con braccioli **NICOLE** 9NK103 cm 56x56x91h e senza braccioli 9NK101 cm 53x56x91 in pelle cat. Super art. Panama col. 5320 e base in rovere tinto wengè.

**NICOLE** chair with high back and armrests 9NK103 cm 56x56x91h and without armrests 9NK101 cm 53x56x91h in leather cat. Super art. Panama col. 5320 and wengè stained oak base.



Sedia alta **NICOLE** 9NK101 cm 53x56x91h e sedie basse **NICOLE** 9NK102 cm 53x56x74h in pelle cat. Super art. Panama col. 5270 con base in rovere tinto antracite e tavolo **MIKE** 7MK102 cm 240x100x73h con gambe in rovere tinto antracite e piano in marmo Emperador marrone lucido.

**NICOLE** chairs with high back 9NK101 cm 53x56x91h and with low back 9NK102 cm 53x56x74h in leather cat. Super art. Panama col. 5270 with charcoal stained oak base and **MIKE** dining table 7MK102 cm 240x100x73h with charcoal stained oak base and shiny Emperador brown marble top.



# Nicole

Design **Studio Marelli** 2015

Fusto in legno multistrato di pioppo curvato. Struttura della seduta in legno multistrato con imbottitura in poliuretano espanso a quote differenziate 30 kg/m<sup>3</sup> e 40 kg/m<sup>3</sup>, rivestito in dacron, con cinghie elastiche intrecciate. Rivestimento fisso. La versione standard è dotata di antiscivolanti in PVC. Disponibili a richiesta altri tipi di antiscivolanti, in feltro e plastica.

Carcasse en bois multiplis de peuplier courbé. Structure de l'assise en bois multiplis finie de mousse de polyuréthane de différentes densités de 30 kg/m<sup>3</sup> et de 40 kg/m<sup>3</sup> couverte de dacron, muni de bandes élastiques entrecroisées. Revêtement fixe. Équipé de patins en PVC dans la version standard. Disponible sur demande avec d'autres patins, en feutre ou en plastique.

Frame made of curved multi-ply poplar wood. Seat structure made of multi-ply wood, upholstered with polyurethane foam in different densities of 30 Kg/m<sup>3</sup> and 40 Kg/m<sup>3</sup>, covered with dacron, with interwoven elastic belts. Fixed covers. The standard version is equipped with PVC glides. Other kinds of glides in plastic or felt pads are available on demand.

Romp in multiplex van gebogen populierenhout. Zitframe in multiplex, bekleed met meerlagig koudschuim met een densiteit van 30 kg/m<sup>3</sup> en 40 kg/m<sup>3</sup>, afgewerkt met dacron, voorzien van door elkaar geweven elastische singels. Vaste bekleding. De standaardversie is voorzien van pvc-glijders. Op aanvraag zijn andere soorten glijders verkrijgbaar, in vilt en kunststof.

Das Gestell besteht aus gebogenem Pappelschichtholz. Sitzstruktur aus Schichtholz, gepolstert mit Polyurethan-Schaumstoff in verschiedenen Dichten 30 Kg/m<sup>3</sup> und 40 Kg/m<sup>3</sup>, mit Dacron ummantelt, mit geflochtenen Gummigurten. Nicole ist immer festbezogen. Standard mit PVC-Gleitern ausgestattet. Andere Gleiter, wie Felt- oder Kunststoffgleiter, sind auf Anfrage verfügbar.

Для производства каркаса используется гнутая многослойная фанера из тополя. Конструкция сиденья выполнена из многослойной фанеры в сочетании с перекрещивающимися эластичными ремнями и наполнением из вспененного пенополиуретана различной степени плотности - 30 кг/м<sup>3</sup> и 40 кг/м<sup>3</sup>, обернутого в дакрон. Чехлы несъемные. В стандартный комплект по умолчанию входят противоскользящие накладки из ПВХ. По запросу возможно их изготовление из войлока или пластика.

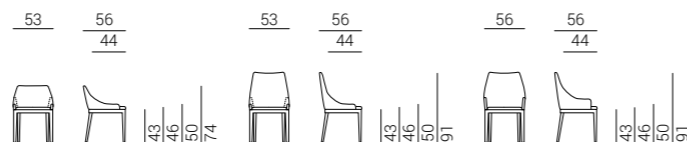
**9NK101**  
L53 P56 H91**9NK102**  
L53 P56 H74**9NK103**  
L56 P56 H91

| Code | Cherry stained oak | Wengé stained oak | Walnut stained oak | Natural oak | Black stained oak | Cherry Milano stained oak | Tobacco stained oak | Grey taupe stained oak | Whitened oak | Charcoal stained oak | Mahogany stained oak |
|------|--------------------|-------------------|--------------------|-------------|-------------------|---------------------------|---------------------|------------------------|--------------|----------------------|----------------------|
| Base | OPR1               | OPR2              | OPR3               | OPR4        | OPR5              | OPR6                      | OPR8                | OPR9                   | OPR10        | OPR11                | OPR12                |

# Ribot

Design **Studio Marelli** 2009**marelli**



Poltrone **RIBOT** 9RB104 cm 78x103x89h e 9RB106 cm 78x103x68h con parte interna in tessuto cat. D art. Creta 2 col. 46 e parte esterna in pelle cat. Super art. Dollaro col. 7110.

***RIBOT** armchairs 9RB104 cm 78x103x89h and 9RB106 cm 78x103x68h with internal part in fabric cat. D art. Creta 2 col. 46 and external part in leather cat. Super art. Dollaro 7110.*





Poltrona e pouf **RIBOT** 9RB101 cm 78x103x89h e 9RB102 cm 62x62x41h con parte interna in tessuto cat. E art. San Mateo col. 17 e parte esterna in pelle cat. Super art. Dollaro col. 7110.

**RIBOT** armchair 9RB101 cm 78x103x68h and pouf 9RB102 cm 62x62x41h with internal part in fabric cat. E art. San Mateo col. 17 and external part in leather cat. Super art. Dollaro col. 7110.



Poltrona **RIBOT** 9RB101 cm 78x103x89h con parte interna in tessuto cat. E art. San Mateo col. 17 e parte esterna in pelle cat. Super art. Dollaro col. 7110. Tavolino **TOM** 7TM102 ø cm 40x50h in tulipier tinto noce.

***RIBOT** armchair 9RB101 cm 78x103x89h with internal part in fabric cat. E art. San Mateo col. 17 and external part in leather cat. Super art. Dollaro col. 7110. **TOM** coffee table 7TM102 ø cm 40x50h in walnut stained tulipier.*

Poltrone **RIBOT** 9RB106 cm 78x103x68h con parte interna in tessuto cat. D art. Creta 2 col. 46 e parte esterna in pelle cat. Super art. Dollaro col. 7110.

***RIBOT** armchairs 9RB106 cm 78x103x68h with internal part in fabric cat. D art. Creta 2 col. 46 and external part in leather cat. Super art. Dollaro 7110.*



# Ribot

Design **Studio Marelli** 2009

# Stone

Design **Studio Marelli** 2009

Fusto in legno massello e legno multistrato con cinghie elastiche intrecciate.  
 Imbottitura della seduta in poliuretano espanso con densità 40 kg/m<sup>3</sup> rivestito in dacron.  
 Imbottitura dello schienale in poliuretano espanso a quote differenziate con densità di 30 kg/m<sup>3</sup> e 40 kg/m<sup>3</sup>, rivestito in dacron.  
 Rivestimento fisso.

Carcasse en bois massif et multiplis munie de bandes élastiques entrecroisées.  
 Assise rembourrée en mousse de polyuréthane d'une densité de 40 kg/m<sup>3</sup> couverte de dacron.  
 Dossier rembourré en mousse polyuréthane de différentes densités de 30 kg/m<sup>3</sup> et 40 kg/m<sup>3</sup> couverte de dacron.  
 Revêtement fixe.

Frame made of solid wood and plywood with interwoven elastic belts.  
 Seat upholstered with polyurethane foam with density of 40 kg/m<sup>3</sup>, covered with dacron.  
 Back upholstered with polyurethane foam with different densities of 30 kg/m<sup>3</sup> and 40 kg/m<sup>3</sup>, covered with dacron.  
 Fixed covers.

Romp in massief hout en multiplex, voorzien van door elkaar geweven elastische singels.  
 Zitvulling in koudschuim met een densiteit van 40 kg/m<sup>3</sup>, bekleed met dacron.  
 Rugvulling in meerlagig koudschuim met een densiteit van 30 kg/m<sup>3</sup> en 40 kg/m<sup>3</sup>, bekleed met dacron.  
 Vaste bekleding.

Das Gestell besteht aus Massiv- und Schichtholz, mit geflochtenen Gummigurten.  
 Sitz gepolstert mit Polyurethan-Schaumstoff 40 Kg/m<sup>3</sup>, mit Dacron bezogen.  
 Rücken gepolstert mit Polyurethan-Schaumstoff in verschiedenen Dichten 30 Kg/m<sup>3</sup> und 40 Kg/m<sup>3</sup>, mit Dacron bezogen.  
 Ribot ist immer festbezogen.

Для производства каркаса используется массив дерева и многослойная фанера в сочетании с перекрещивающимися эластичными ремнями. Наполнение сиденья из вспененного пенополиуретан плотностью - 30 кг/м<sup>3</sup>, обернутого в дакрон.  
 Наполнение спинки из вспененного пенополиуретана различной степени плотности - 30 кг/м<sup>3</sup> и 40 кг/м<sup>3</sup>, обернутого в дакрон.  
 Чехлы несъемные.



**9RB101**  
L78 P103 H89



**9RB102**  
L62 P62 H41



**9RB103**  
L78 P103 H68



**9RB107**  
L200 P103 H68



**9RB104**  
L78 P103 H89



**9RB105**  
L62 P62 H41



**9RB106**  
L78 P103 H68



**9RB108**  
L200 P103 H68



| Code | Cherry stained beech | Wengè stained beech | Walnut stained beech | Natural beech | Black stained beech | Cherry Milano stained beech | Tobacco stained beech | Grey taupe stained beech | Charcoal stained beech | Mahogany stained beech |
|------|----------------------|---------------------|----------------------|---------------|---------------------|-----------------------------|-----------------------|--------------------------|------------------------|------------------------|
| Base | <b>OPF1</b>          | <b>OPF2</b>         | <b>OPF3</b>          | <b>OPF4</b>   | <b>OPF5</b>         | <b>OPF6</b>                 | <b>OPF8</b>           | <b>OPF9</b>              | <b>OPF11</b>           | <b>OPF12</b>           |



**marelli**

Composizione **MATHEUS** cm 300x200 con cuscini con fascia 9MU101 cm 50x50 e 9MU102 cm 60x60 in tessuto cat. E art. San Mateo col. 17 e cuscino con fascia 9VR101 cm 45x45 e senza fascia 9CU106 cm 45x45 in pelle cat. Super art. Dollaro col. 7110. Tavolini **STONE** 7ST110 cm 95x95x27h

con base in rovere tinto antracite e top in marmo Calacatta oro lucido e 7ST112 cm 120x45x27h con base in rovere tinto wengè e top in marmo Calacatta oro lucido. Tavolino **CIRCLE** 7CR111 ø cm 60x40h con base in metallo cromo nero lucido e top in vetro grigio retroverniciato cromo.

**MATHEUS** composition cm 300x200 with cushions with band 9MU101 cm 50x50 and 9MU102 cm 60x60 in fabric cat. E art. San Mateo col. 17 and cushion with band 9VR101 cm 45x45 and without band 9CU106 cm 45x45 in leather cat. Super art. Dollaro col. 7110. **STONE** tables 7ST110 cm 95x95x27h with

charcoal stained oak base and shiny Calacatta gold marble top and 7ST112 cm 120x45x27h with wengè stained oak base and shiny Calacatta gold marble top. **CIRCLE** coffee table 7CR111 ø cm 60x40h with shiny black chrome base and chrome back-painted grey glass.



Divano **MATHEUS** 9MU203 cm 220x100x62h con cuscini con fascia 9MU101 cm 50x50 e 9MU102 cm 60x60 in tessuto cat. E Art. Fauna col. 166  
Tavolini **STONE** 7ST110 cm 95x95x27h con base in rovere tinto antracite e top in marmo Perfetto brown opaco. Tavolini **TWINS** 7TW113 cm 45x45x37h e 7TW104 ø cm 51x51h con base in rovere tinto antracite e top in marmo Perfetto Brown opaco.

**MATHEUS** sofa 9MU203 cm 220x100x62h with cushions with band 9MU101 cm 50x50 and 9MU102 cm 60x60 in fabric cat. E Art. Fauna col. 166  
**STONE** tables 7ST110 cm 95x95x27h with charcoal stained oak base and matt Perfetto brown marble top. **TWINS** tables 7TW113 cm 45x45x37h and 7TW104 cm 51x51h with charcoal stained oak base and matt Perfetto brown marble top.



Dettaglio di tavolino **STONE** con base in rovere tinto antracite e top in marmo nero Marquinia lucido.

*Detail of **STONE** table with charcoal stained oak base and shiny black Marquinia marble top.*





Tavolini **STONE** 7ST101 cm 60x60x40h e 7ST104 cm 95x95x27h con base in rovere tinto wengé e top in pietra Serena grigia e tavolini 7ST101 cm 60x60x40h e 7ST103 cm 35x35x40h con base in rovere tinto noce e

**STONE** coffee tables 7ST101 cm 60x60x40h and 7ST104 cm 95x95x27h with wengé stained oak base and grey Serena stone top and 7ST101 cm 60x60x40h and 7ST103 cm 35x35x40h with walnut stained oak base and

# Stone

Design **Studio Marelli** 2009

Base:  
rovere impiallacciato, sezione 30 mm.

Top:

- pietra, spessore 15 mm. nelle seguenti finiture:
  - pietra Serena grigia
  - pietra di Brera beige
- marmo, spessore 15 mm. disponibile nei seguenti colori:
  - bianco Carrara
  - nero Marquinia
  - marrone Emperador
  - Perfetto brown
  - Calacatta oro
  - Black & Gold

finiture disponibili per il marmo:

- lucido
- opaco
- vetro temperato extra light, spessore 6 mm, disponibile nelle seguenti finiture:
  - vetro trasparente
  - vetro satinato
  - vetro lucido o, su richiesta, opaco, retroverniciato:
    - RAL 9016 bianco traffico
    - RAL 9017 nero traffico
    - RAL 7044 grigio seta
    - RAL 1019 beige grigiastro
    - RAL 7006 grigio beige
    - vetro bronzato retroverniciato cromo
    - vetro grigio retroverniciato cromo
    - tutti gli altri colori RAL standard disponibili su richiesta

Optional su richiesta: base in rovere verniciato a poro aperto nei colori RAL Classic, opaco.

Base: oak veneer, section 30 mm.

Top:

- stone, 15 mm thick, available in the following finishes:
  - grey Serena stone
  - beige Brera stone
- marble, 15 mm thick, available in the following colours:
  - Carrara white
  - Marquinia black
  - Emperador brown
  - Perfetto brown
  - Calacatta gold
  - Black & Gold

available marble finishes:

- shiny
- matt
- tempered extra light glass, 6 mm thick, available in the following finishes:
  - transparent glass
  - frosted glass
  - shiny or, on demand, matt, back-painted glass:
    - RAL 9016 traffic white
    - RAL 9017 traffic black
    - RAL 7044 silk grey
    - RAL 1019 grey beige
    - RAL 7006 beige grey
    - chrome back-painted bronze glass
    - chrome back-painted grey glass
    - all other RAL Classic colours are available on demand

Option on demand: oak base open pore painted in all RAL Classic colours, matt.

Gestell: Eiche furniert, 30 x 30 mm.

Platte:

- Stein, Plattenstärke 15 mm, in den folgenden Ausführungen erhältlich:
  - Serena grau
  - Brera beige
- Marmor: Plattenstärke 15 mm, in den folgenden Farben erhältlich:
  - Carrara weiß
  - Marquinia schwarz
  - Emperador braun
  - Perfetto braun
  - Calacatta gold
  - Black & Gold

Mögliche Ausführungen für den Marmor:

- glänzend
- matt
- gehärtetes Extra Light-Glas, Glasplattenstärke 6 mm, in den folgenden Ausführungen erhältlich:
  - Klarglas
  - Mattglas
  - von hinten lackiertes Glas, glänzend oder auf Anfrage matt:
    - RAL 9016 verkehrsweiß
    - RAL 9017 verkehrsschwarz
    - RAL 7044 seidengrau
    - RAL 1019 graubeige
    - RAL 7006 beige grau
  - von hinten chromlackiertes Bronzenglas
  - von hinten chromlackiertes Grauglas
  - alle anderen RAL Classic-Farben sind auf Anfrage erhältlich

Option auf Anfrage: Eichengestell offenporig lackiert in allen RAL Classic-Farben, matt.



# Stone

Design **Studio Marelli** 2009**Piètement:**

chêne plaqué, section 30 mm.

**Plateau:**

- pierre, épaisseur 15 mm, disponible dans les finitions suivantes:
- pierre Serena gris
- pierre Brera beige
- marbre, épaisseur 15 mm, disponible dans les couleurs suivantes:
- blanc Carrara
- noir Marquinia
- brun Emperador
- brun Perfetto
- or Calacatta
- Black & Gold

**Finitions disponibles du marbre:**

- brillant
- mat
- Verre trempé extra clair, épaisseur 6 mm, disponible dans les finitions suivantes:
- verre transparent
- verre dépoli
- verre brillant ou mat laqué par dessous:
- RAL 9016 blanc signalisation
- RAL 9017 noir signalisation
- RAL 7044 gris soie
- RAL 1019 beige gris
- RAL 7006 gris beige
- verre bronzé laqué chrome par dessous
- verre gris laqué chrome par dessous
- toutes les autres couleurs RAL Classic sont disponibles sur demande

Option sur demande: piètement en chêne laqué à pores ouverts dans toutes les couleurs RAL Classic, mat.

**Onderstel:**

eik finer, sectie 30 mm.

**Blad:**

- steen, dikte 15 mm, verkrijgbaar in de volgende kleuren:
- steen Serena grijs
- steen Brera beige
- marmer, dikte 15 mm, verkrijgbaar in de volgende afwerkingen:
- Carrara White
- Marquinia Black
- Emperador Brown
- Perfetto Brown
- Calacatta Gold
- Black & Gold

**Mogelijke afwerkingen voor het marmer:**

- glanzend
- mat
- Getemperd extrahelder glas, dikte 6 mm, verkrijgbaar in de volgende afwerkingen:
- helder glas
- matglas
- glanzend of mat glas, aan de onderkant gelakt:
- RAL 9016 verkeerswit
- RAL 9017 verkeerszwart
- RAL 7044 zijdegrijs
- RAL 1019 grijsbeige
- RAL 7006 beigegrijs
- aan de onderkant chroomgelakt bronsglas
- aan de onderkant chroomgelakt grijs glas
- alle andere RAL Classic-kleuren zijn op aanvraag verkrijgbaar

Optie op aanvraag: eiken onderstel openporig gelakt in alle RAL Classic-kleuren, mat.

**Каркас:**













дуб сечением 30мм, фанерованный шпоном

**Столешница:**

- Натуральный камень толщиной 15мм, возможные варианты:
- pietra Serena grigia (серый)
- pietra di Brera beige (бежевый)
- Мрамор толщиной 15мм, возможные варианты:
- bianco Carrara
- nero Marquinia
- marrone Emperador
- perfetto brown
- Calacatta oro

**Варианты отделки:**

- глянцевая
  - матовая
  - Закаленное стекло extra light, толщина 6мм, варианты:
  - прозрачное
  - сатинированное
  - глянцевое, и по запросу матовое, варианты окраски с тыльной стороны:
  - RAL 9016 дорожно – белый
  - RAL 9017 дорожно – черный
  - RAL 7044 шелково – серый
  - RAL 1019 бежево – серый
  - RAL 7006 серо - бежевый
  - бронза, с тыльной стороны хром
  - серый, с тыльной стороны хром
  - по запросу: любой цвет по палитре RAL Classic
- По запросу возможно изготовление каркаса из окрашенного дуба в матовой отделке с видимой структурой дерева, в цветах по палитре RAL Classic.

|  |  |  |  |  |   |
|--|--|--|--|--|---|
|                      |                     |                     |                     |                    |                    |
|                      |                     |                     |                     |                    |                    |
| <b>7ST101</b><br>Stone top<br><b>7ST107</b><br>Marble top<br><b>7ST113</b><br>Glass top<br>L60 P60 H40 | <b>7ST102</b><br>Stone top<br><b>7ST108</b><br>Marble top<br><b>7ST114</b><br>Glass top<br>L35 P35 H50 | <b>7ST103</b><br>Stone top<br><b>7ST109</b><br>Marble top<br><b>7ST115</b><br>Glass top<br>L35 P35 H40 | <b>7ST104</b><br>Stone top<br><b>7ST110</b><br>Marble top<br><b>7ST116</b><br>Glass top<br>L95 P95 H27 | <b>7ST106</b><br>Stone top<br><b>7ST111</b><br>Marble top<br><b>7ST117</b><br>Glass top<br>L95 P95 H40 | <b>7ST105</b><br>Stone top<br><b>7ST112</b><br>Marble top<br><b>7ST118</b><br>Glass top<br>L120 P45 H27 |

|                            |   |  |  |   |   |   |   |                                       |  |                                 |
|----------------------------|---|--|--|---|---|---|---|---------------------------------------|--|---------------------------------|
|                            | Grey<br>Serena stone<br><b>OPP4</b>     | Beige<br>Brera stone<br><b>OPP5</b>      |  |   |   |   |   |                                       |  |                                 |
| <b>Code</b><br>Stone top   | ●                                       | ●  |  |   |   |   |   |                                       |  |                                 |
|                            | White Carrara<br>marble<br><b>OPP1</b>  | Black Marquinia<br>marble<br><b>OPP2</b> | Brown Emperador<br>marble<br><b>OPP3</b> | Perfetto brown<br>marble<br><b>OPP6</b> | Calacatta gold<br>marble<br><b>OPP7</b> | Black and Gold<br>marble<br><b>OPP9</b>     |   |                                       |  |                                 |
| <b>Code</b><br>Marble top  | ●                                       | ●  | ●  | ●                                       | ●                                       | ●   |   |                                       |  |                                 |
|                            | Cherry<br>stained oak<br><b>OPR1</b>    | Wengé<br>stained oak<br><b>OPR2</b>      | Walnut<br>stained oak<br><b>OPR3</b>     | Natural<br>oak<br><b>OPR4</b>           | Black<br>stained oak<br><b>OPR5</b>     | Cherry Milano<br>stained oak<br><b>OPR6</b> | Aluminium<br>stained oak<br><b>OPR7</b> | Tobacco<br>stained oak<br><b>OPR8</b> | Grey taupe<br>stained oak<br><b>OPR9</b> | Whitened<br>oak<br><b>OPR10</b> |
| <b>Code</b><br>Wooden base | ●                                       | ●  | ●  | ●                                       | ●                                       | ●   | ●                                       | ●                                     | ●  | ●                               |
|                            | Charcoal<br>stained oak<br><b>OPR11</b> | Mahogany<br>stained oak<br><b>OPR12</b>  |  |   |   |   |   |                                       |  |                                 |
| <b>Code</b><br>Wooden base | ●                                       | ●  |  |   |   |   |   |                                       |  |                                 |

# Tab

Design **Paolo Salvadé** 2014**marelli**



Tavolo **TAB** 7TAB114 ø cm 125x36h con struttura in metallo cromo nero lucido, piano inferiore in vetro grigio retroverniciato cromo e piano superiore in marmo Calacatta oro lucido.

**TAB** table 7TAB114 ø 125x36h with shiny black chrome metal structure, chrome back-painted grey glass lower top and shiny Calacatta gold marble upper top.



Tavolo **TAB** 7TAB114 ø cm 125x36h con struttura in metallo cromo nero lucido, piano inferiore in vetro grigio retroverniciato cromo e piano superiore in marmo Calacatta oro lucido.

**TAB** table 7TAB114 ø 125x36h with shiny black chrome metal structure, chrome back-painted grey glass lower top and shiny Calacatta gold marble upper top.

Tavolo **TAB** 7TAB116 cm 90x90x36h con struttura in metallo spazzolato canna di fucile, piano inferiore in vetro bronzato retroverniciato cromo e piano superiore in marmo Emperador marrone lucido.

**TAB** table 7TAB116 cm 90x90x36h with brushed matt dark grey metal structure, chrome back-painted bronze glass lower top and shiny Emperador brown upper top.



Tavolo **TAB** 7TAB114 ø cm 125x36h con struttura verniciata classic bronze, piano superiore in marmo Emperador marrone lucido e piano inferiore in vetro retroverniciato RAL 9017 nero opaco. Tavoli **TAB** 7TAB105 cm 65x65x36h e 7TAB107 cm 127x54x36h con struttura verniciata classic bronze, piano superiore in marmo Perfetto Brown opaco e piano inferiore in noce Canaletto.

**TAB** coffee table 7TAB114 ø cm 125x36h with classic bronze painted metal structure, shiny Emperador brown marble upper top and RAL 9017 matt black back-painted glass lower top. **TAB** tables 7TAB105 cm 65x65x36h and 7TAB107 cm 127x54x36h with classic bronze painted metal structure, matt Perfetto Brown upper top and Canaletto walnut lower top.













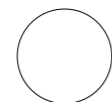

Tavolini **TAB** 7TAB116 cm 90x90x36h con struttura in metallo spazzolato canna di fucile, piano inferiore in vetro bronzato retroverniciato cromo e piano superiore in marmo Emperador marrone lucido.

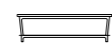
**TAB** tables 7TAB116 cm 90x90x36h with brushed matt dark grey metal structure, chrome back-painted bronze glass lower top and shiny Emperador brown upper top.



# Tab

Design **Paolo Salvadé** 2014

|   |   |  |  |
|---|---|--|--|
|    |    |   |   |
|    |    |   |   |
| <p><b>7TAB101</b><br/>Marble upper top<br/>Canaletto walnut veneer<br/>lower top<br/><b>7TAB111</b><br/>Marble upper top<br/>Glass lower top<br/><b>7TAB121</b><br/>Glass upper top<br/>Glass lower top<br/>Ø60 H36</p>     | <p><b>7TAB102</b><br/>Marble upper top<br/>Canaletto walnut veneer<br/>lower top<br/><b>7TAB112</b><br/>Marble upper top<br/>Glass lower top<br/><b>7TAB122</b><br/>Glass upper top<br/>Glass lower top<br/>Ø60 H50</p>     | <p><b>7TAB103</b><br/>Marble upper top<br/>Canaletto walnut veneer<br/>lower top<br/><b>7TAB113</b><br/>Marble upper top<br/>Glass lower top<br/><b>7TAB123</b><br/>Glass upper top<br/>Glass lower top<br/>Ø90 H36</p>      | <p><b>7TAB104</b><br/>Marble upper top<br/>Canaletto walnut veneer<br/>lower top<br/><b>7TAB114</b><br/>Marble upper top<br/>Glass lower top<br/><b>7TAB124</b><br/>Glass upper top<br/>Glass lower top<br/>Ø125 H36</p>     |
|    |    |   |   |
|    |    |   |   |
| <p><b>7TAB105</b><br/>Marble upper top<br/>Canaletto walnut veneer<br/>lower top<br/><b>7TAB115</b><br/>Marble upper top<br/>Glass lower top<br/><b>7TAB125</b><br/>Glass upper top<br/>Glass lower top<br/>L65 P65 H36</p> | <p><b>7TAB106</b><br/>Marble upper top<br/>Canaletto walnut veneer<br/>lower top<br/><b>7TAB116</b><br/>Marble upper top<br/>Glass lower top<br/><b>7TAB126</b><br/>Glass upper top<br/>Glass lower top<br/>L90 P90 H36</p> | <p><b>7TAB107</b><br/>Marble upper top<br/>Canaletto walnut veneer<br/>lower top<br/><b>7TAB117</b><br/>Marble upper top<br/>Glass lower top<br/><b>7TAB127</b><br/>Glass upper top<br/>Glass lower top<br/>L127 P54 H36</p> | <p><b>7TAB108</b><br/>Marble upper top<br/>Canaletto walnut veneer<br/>lower top<br/><b>7TAB118</b><br/>Marble upper top<br/>Glass lower top<br/><b>7TAB128</b><br/>Glass upper top<br/>Glass lower top<br/>L120 P70 H36</p> |

|             |  |   |   |   |   |  |  |  |  |
|-------------|--|---|---|---|---|--|--|--|--|
| <b>Code</b> | RAL 9016 traffic white<br><b>OPV3</b>  | RAL 9017 traffic black<br><b>OPV4</b>       | RAL 7044 silk grey<br><b>OPV5</b>           | RAL 1019 grey beige<br><b>OPV6</b>          | RAL standard colours<br><b>OPV7</b>         | Chrome back-painted bronze glass<br><b>OPV9</b>    | Chrome back-painted grey glass<br><b>OPV10</b> |  |  |
| Glass top   | ●                                      | ●   | ●   | ●   | ●   | ●  | ●  |  |  |
| <b>Code</b> | White Carrara marble<br><b>OPP1</b>    | Black Marquina marble<br><b>OPP2</b>        | Brown Emperador marble<br><b>OPP3</b>       | Perfetto brown marble<br><b>OPP6</b>        | Calacatta gold marble<br><b>OPP7</b>        | Black and Gold marble<br><b>OPP9</b>               |  |  |  |
| Marble top  | ●                                      | ●   | ●   | ●   | ●   | ●  |  |  |  |
| <b>Code</b> | Canaletto walnut veneer<br><b>OPN1</b> |   |   |   |   |  |  |  |  |
| Wooden top  | ●                                      |   |   |   |   |  |  |  |  |
| <b>Code</b> | Shiny chrome metal<br><b>OPM1</b>      | Brushed matt metal<br><b>OPM2</b>           | Brushed matt dark grey metal<br><b>OPM3</b> | RAL 9017 black painted metal<br><b>OPM6</b> | RAL 9016 white painted metal<br><b>OPM7</b> | Metal painted in RAL Classic colors<br><b>OPM8</b> | Classic bronze painted metal<br><b>OPM9</b>    | Golden beach painted metal<br><b>OPM10</b> | Gold pearl painted metal<br><b>OPM11</b> |
| Metal       | ●                                      | ●   | ●   | ●   | ●   | ●  | ●  | ●  | ●  |
| <b>Code</b> | Brushed copper metal<br><b>OPM12</b>   | Brushed antique brass metal<br><b>OPM13</b> | Shiny black chrome metal<br><b>OPM14</b>    | Brushed antique gold metal<br><b>OPM15</b>  |   |  |  |  |  |
| Metal       | ●                                      | ●   | ●   | ●   |   |  |  |  |  |

# Tab

Design **Paolo Salvadé** 2014

Base:  
metallo, sezione 10 mm, disponibile nelle seguenti finiture:

- cromo lucido
- spazzolato cromo satinato
- spazzolato canna di fucile
- spazzolato rame
- spazzolato ottone antico
- cromo nero lucido
- spazzolato oro antico
- verniciato RAL 9017 nero traffico
- verniciato RAL 9016 bianco traffico
- verniciato classic bronze
- verniciato golden beach
- verniciato gold pearl
- verniciato in tutti gli altri colori RAL Classic

Piano superiore:

- vetro temperato extra light, spessore 6 mm, lucido o opaco, retroverniciato nelle seguenti finiture:
  - RAL 9016 bianco traffico
  - RAL 9017 nero traffico
  - RAL 7044 grigio seta
  - RAL 1019 beige grigiastro
  - bronzato retroverniciato cromo
  - grigio retroverniciato cromo
  - tutti gli altri colori RAL Classic disponibili su richiesta
- marmo, spessore 20 mm, lucido o opaco, disponibile nei seguenti colori:
  - bianco Carrara
  - nero Marquina
  - marrone Emperador
  - Perfetto brown
  - Calacatta oro
  - Black & Gold

Piano inferiore:

- vetro temperato extra light, spessore 6 mm, lucido o opaco, retroverniciato nelle seguenti finiture:
  - RAL 9016 bianco traffico
  - RAL 9017 nero traffico
  - RAL 7044 grigio seta
  - RAL 1019 beige grigiastro
  - bronzato retroverniciato cromo
  - grigio retroverniciato cromo
  - tutti gli altri colori RAL Classic disponibili su richiesta
- legno impiallacciato noce canaletto, spessore 20 mm

Base:

metal, section 10 mm, available in the following finishes:

- shiny chrome
- brushed matt chrome
- brushed matt dark grey
- brushed copper
- brushed antique brass
- shiny black chrome
- brushed antique gold
- painted RAL 9017 traffic black
- painted RAL 9016 traffic white
- painted classic bronze
- painted golden beach
- painted gold pearl
- painted in all other RAL Classic colours

Upper top:

- tempered extra light glass, 6 mm thick, shiny or matt, back-painted in the following finishes:
  - RAL 9016 traffic white
  - RAL 9017 traffic black
  - RAL 7044 silk grey
  - RAL 1019 grey beige
  - chrome back-painted bronze
  - chrome back-painted grey
  - all other RAL Classic colours available on demand
- marble, 20 mm thick, available in the following colours:
  - Carrara white
  - Marquina black
  - Emperador brown
  - Perfetto brown
  - Calacatta gold
  - Black & Gold

Lower top:

- tempered extra light glass, 6 mm thick, shiny or matt, back-painted in the following finishes:
  - RAL 9016 traffic white
  - RAL 9017 traffic black
  - RAL 7044 silk grey
  - RAL 1019 grey beige
  - chrome back-painted bronze
  - chrome back-painted grey
  - all other RAL Classic colours available on demand
- Canaletto walnut veneer, 20 mm thick

Gestell:

Metall, 4-Kant-Stahlrohr 10 x 10 mm, in den folgenden Ausführungen erhältlich:

- glänzend verchromt
- matt verchromt gebürstet
- dunkelgrau gebürstet
- Kupfer gebürstet
- antik Messing gebürstet
- glänzend verchromt schwarz
- antik Gold gebürstet
- RAL 9016 verkehrsschwarz lackiert
- RAL 9017 verkehrsweiß lackiert
- classic bronze lackiert
- golden beach lackiert
- gold pearl lackiert
- in allen anderen RAL Classic-Farben lackiert

Obere Platte:

- gehärtetes Extra Light-Glas, Glasplattenstärke 6 mm, glänzend oder matt, von hinten lackiert in den folgenden Ausführungen:
  - RAL 9016 verkehrsweiß
  - RAL 9017 verkehrsschwarz
  - RAL 7044 seidengrau
  - RAL 1019 graubeige
  - Bronze von hinten chromlackiert
  - grau von hinten chromlackiert
  - alle anderen RAL Classic-Farben auf Anfrage erhältlich
- Marmor, Plattenstärke 20 mm, glänzend oder matt, in den folgenden Farben erhältlich:
  - Carrara weiß
  - Marquina schwarz
  - Emperador braun
  - Perfetto braun
  - Calacatta gold
  - Black & Gold

Untere Platte:

- gehärtetes Extra Light-Glas, Glasplattenstärke 6 mm, glänzend oder matt, in den folgenden Ausführungen erhältlich:
  - RAL 9016 verkehrsweiß
  - RAL 9017 verkehrsschwarz
  - RAL 7044 seidengrau
  - RAL 1019 graubeige
  - Bronze von hinten chromlackiert
  - grau von hinten chromlackiert
  - alle anderen RAL Classic-Farben auf Anfrage erhältlich
- Nussbaum Canaletto furniert, Plattenstärke 20 mm

# Tab

Design **Paolo Salvadé** 2014

Piètement: métal, section 10 mm, disponible dans les finitions suivantes:

- chromé brillant
- brossé chromé mat
- brossé canon de fusil
- brossé cuivre
- brossé laiton antique
- chromé brillant noir
- brossé or antique
- laqué RAL 9017 noir signalisation
- laqué RAL 9016 blanc signalisation
- laqué classic bronze
- laqué golden beach
- laqué gold pearl
- laqué dans toutes les autres couleurs RAL Classic

Plateau supérieur:

- verre trempé extra clair, épaisseur 6 mm, brillant ou mat, laqué par dessous dans les finitions suivantes:
- RAL 9016 blanc signalisation
- RAL 9017 noir signalisation
- RAL 7044 gris soie
- RAL 1019 beige gris
- bronzé laqué au chrome par dessous
- gris laqué au chrome par dessous
- toutes les autres couleurs RAL Classic disponibles sur demande
- marbre, épaisseur 20 mm, disponible dans les couleurs suivantes:
- blanc Carrara
- noir Marquinia
- brun Emperador
- brun Peretto
- or Calacatta
- Black & Gold

Plateau inférieur:

- verre trempé extra clair, épaisseur 6 mm, brillant ou mat, laqué par dessous dans les finitions suivantes:
- RAL 9016 blanc signalisation
- RAL 9017 noir signalisation
- RAL 7044 gris soie
- RAL 1019 beige gris
- bronzé laqué au chrome par dessous
- gris laqué au chrome par dessous
- toutes les autres couleurs RAL Classic disponibles sur demande
- noyer «Canaletto» plaqué, épaisseur 20 mm

Onderstel: metaal, sectie 10 mm, verkrijgbaar in de volgende afwerkingen:

- glanschroom
- geborsteld matchroom
- geborsteld canon de fusil
- geborsteld koper
- geborsteld antiek messing
- glanschroom zwart
- geborsteld antiek goud
- RAL 9017 verkeerszwart gelakt
- RAL 9016 verkeerswit gelakt
- classic bronze gelakt
- golden beach gelakt
- gold pearl gelakt
- gelakt in alle andere RAL Classic-kleuren

Bovenblad:

- getemperd extrahelder glas, dikte 6 mm, glanzend of mat, aan de onderkant gelakt in de volgende afwerkingen:
- RAL 9016 verkeerswit
- RAL 9017 verkeerszwart
- RAL 7044 zijdegrijs
- RAL 1019 grijsbeige
- brons aan de onderkant chroomgelakt
- grijs aan de onderkant chroomgelakt
- alle andere RAL Classic-kleuren op aanvraag verkrijgbaar
- marmer, bladdikte 20 mm, glanzend of mat, verkrijgbaar in de volgende kleuren:
- Carrara White
- Marquinia Black
- Emperador Brown
- Peretto Brown
- Calacatta Gold
- Black & Gold

Onderblad:

- getemperd extrahelder glas, dikte 6 mm, glanzend of mat, aan de onderkant gelakt in de volgende afwerkingen:
- RAL 9016 verkeerswit
- RAL 9017 verkeerszwart
- RAL 7044 zijdegrijs
- RAL 1019 grijsbeige
- brons aan de onderkant chroomgelakt
- grijs aan de onderkant chroomgelakt
- alle andere RAL Classic-kleuren op aanvraag verkrijgbaar
- «Canaletto»-noten fineer, bladdikte 20 mm

Каркас выполнен из металла сечением 10мм, варианты цветов отделки:

- хром глянцевый
- хром сатинированный спаццолато (см. примечание)
- темно-серый (canna di fucile) спаццолато
- латунь спаццолато
- состаренная медь спаццолато
- хром черный глянцевый
- золото состаренное спаццолато
- RAL 9017 дорожно • черный
- RAL 9016 дорожно – белый
- классический бронзовый
- золотой песок (golden beach)
- золотой жемчуг (gold pearl)
- любой цвет по палитре RAL Classic

Примечание: spazzolato – вид отделки поверхности, при котором она обрабатывается специальными щетками, в результате чего создается декоративный эффект неровности.

Верхняя столешница

- Закаленное стекло extra light, толщина 6мм, глянцевое либо матовое, варианты цветов отделки:
- RAL 9016 дорожно – белый
- RAL 9017 дорожно • черный
- RAL 7044 шелково – серый
- RAL 1019 бежево – серый
- бронза, с тыльной стороны хром
- серый, с тыльной стороны хром
- По запросу: любой цвет по шкале RAL Classic
- Мрамор, глянцевый либо матовый, толщиной 20мм, варианты:
- bianco Carrara
- nero Marquina
- marrone Emperador
- peretto brown
- Calacatta oro
- Black and Gold

Нижняя столешница

- Закаленное стекло extra light, толщина 6мм, глянцевое либо матовое, варианты цветов отделки:
- RAL 9016 дорожно – белый
- RAL 9017 дорожно • черный
- RAL 7044 шелково – серый
- RAL 1019 бежево – серый
- бронза, с тыльной стороны хром
- серый, с тыльной стороны хром
- По запросу: любой цвет по шкале RAL Classic
- Массив дерева, толщина 20мм, фанерованный шпоном ореха каналетто

# Twins

Design **Studio Marelli** 2015**marelli**

Tavolini **TWINS** 7TW113 cm 45x45x37h e 7TW104 ø cm 51x51h con base in rovere tinto antracite e top in marmo Perfetto Brown opaco.

**TWINS** tables 7TW113 cm 45x45x37h and 7TW104 ø cm 51x51h with charcoal stained oak base and matt Perfetto brown marble top.



Serie di tavolini **TWINS**: 7TW101 ø cm 51x37h in rovere tinto antracite, 7TW104 ø cm 51x51h con base in rovere tinto antracite e top in marmo Perfetto brown opaco, 7TW113 cm 45x45x37h con base in rovere tinto antracite e top in marmo Perfetto brown opaco e 7TW112 cm 45x45x51h in rovere tinto antracite.

Series of **TWINS** coffee tables: 7TW101 ø cm 51x37h in charcoal stained oak, 7TW104 ø cm 51x51h with charcoal stained oak base and matt Perfetto brown marble top, 7TW113 cm 45x45x37 with charcoal stained oak base and matt Perfetto brown marble top and 7TW112 cm 45x45x51h in charcoal stained oak.



Tavolini **TWINS** 7TW113 cm 45x45x37h e 7TW114 cm 45x45x51h con base in rovere tinto antracite e top in marmo Calacatta oro lucido. Composizione **MATHEUS** in tessuto cat. E art. San Mateo col. 17.

***TWINS** coffee tables 7TW113 cm 45x45x37h and 7TW114 cm 45x45x51h with charcoal stained oak base and shiny Calacatta gold marble top. **MATHEUS** composition in fabric cat. E art. San Mateo col. 17.*



Tavolini **TWINS** 7TW113 cm 45x45x37h e 7TW114 cm 45x45x51h con base in rovere tinto antracite e top in marmo Calacatta oro lucido. Tavolini **TWINS** 7TW101 ø cm 51x37h e 7TW102 ø cm 51x51h in rovere tinto antracite.

***TWINS** coffee tables 7TW113 cm 45x45x37h and 7TW114 cm 45x45x51h with charcoal stained oak base and shiny Calacatta gold marble top. **TWINS** coffee tables 7TW101 ø cm 51x37h and 7TW102 ø cm 51x51h in charcoal stained oak.*





Tavolini **TWINS** 7TW111 cm 45x45x37h, 7TW112 cm 45x45x51h, 7TW101 ø cm 51x37h e 7TW102 ø cm 51x51h in rovere verniciato RAL 3002 rosso carminio e 7TW101 ø cm 51x37h e 7TW102 ø cm 51x51h in rovere verniciato RAL 7001 grigio argento.

**TWINS** coffee tables 7TW111 cm 45x45x37h, 7TW112 cm 45x45x51h, 7TW101 ø cm 51x37h and 7TW102 ø cm 51x51h in oak painted in colour RAL 3002 carmine red and 7TW101 ø cm 51x37h and 7TW102 ø cm 51x51h in oak painted in colour RAL 7001 silver grey.



# Twins

Design **Studio Marelli** 2015

Base:  
rovere massello, sezione 33 x 33 mm  
Top:  
• rovere impiallacciato, spessore 20 mm  
• marmo, spessore 20 mm, disponibile nelle seguenti finiture, lucido o opaco:  
· bianco Carrara  
· nero Marquinia  
· Emperador marrone  
· Perfetto brown  
· Calacatta oro  
· Black and Gold

Piètement:  
chêne massif, section 33 x 33 mm  
Plateau:  
• placage de chêne, épaisseur 20 mm  
• marbre, épaisseur 20 mm, disponible dans les finitions suivantes, brillant ou mat:  
· blanc Carrara  
· noir Marquinia  
· brun Emperador  
· brun Perfetto  
· or Calacatta  
· Black & Gold

Base:  
solid oak, section 33 x 33 mm  
Top:  
• Oak veneer, 20 mm thick  
• marble, 20 mm thick, available in the following finishes, shiny or matt:  
· Carrara white  
· Marquinia black  
· Emperador brown  
· Perfetto brown  
· Calacatta gold  
· Black and Gold

Onderstel:  
massief eiken, sectie 33 x 33 mm  
Blad:  
• eiken fineer, dikte 20 mm  
• marmer, dikte 20 mm, verkrijgbaar in de volgende afwerkingen, glanzend of mat:  
· Carrara White  
· Marquinia Black  
· Emperador Brown  
· Perfetto Brown  
· Calacatta Gold  
· Black & Gold

Gestell:  
Eiche furniert, quadratisch 33 x 33 mm  
Platte:  
• Eiche furniert, Plattenstärke 20 mm  
• Marmor, Plattenstärke 20 mm, in den folgenden Ausführungen lieferbar, glänzend oder matt:  
· Carrara weiss  
· Marquinia schwarz  
· Emperador braun  
· Perfetto braun  
· Calacatta gold  
· Black and Gold

Каркас:  
массив дуба сечением 33x33мм  
Столешница:  
• дуб толщиной 20мм, фанерованный шпоном  
• мрамор толщиной 20мм, глянцевый либо матовый, варианты:  
· bianco Carrara  
· nero Marquinia  
· Emperador marrone  
· Perfetto brown  
· Calacatta oro  
· Black and Gold

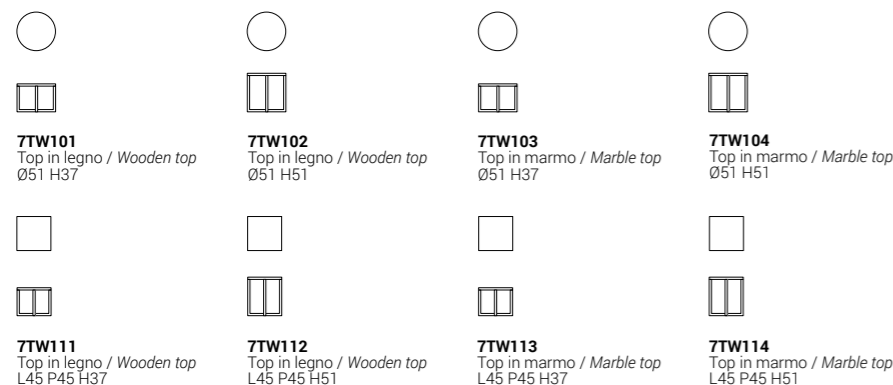

|             |                      |                        |                        |                       |                       |                           |                     |                        |              |                      |                      |
|-------------|----------------------|------------------------|------------------------|-----------------------|-----------------------|---------------------------|---------------------|------------------------|--------------|----------------------|----------------------|
|             | Cherry stained oak   | Wengé stained oak      | Walnut stained oak     | Natural oak           | Black stained oak     | Cherry Milano stained oak | Tobacco stained oak | Grey taupe stained oak | Whitened oak | Charcoal stained oak | Mahogany stained oak |
| <b>Code</b> | <b>OPR1</b>          | <b>OPR2</b>            | <b>OPR3</b>            | <b>OPR4</b>           | <b>OPR5</b>           | <b>OPR6</b>               | <b>OPR8</b>         | <b>OPR9</b>            | <b>OPR10</b> | <b>OPR11</b>         | <b>OPR12</b>         |
| Oak         | ●                    | ●                      | ●                      | ●                     | ●                     | ●                         | ●                   | ●                      | ●            | ●                    | ●                    |
|             | White Carrara marble | Black Marquinia marble | Brown Emperador marble | Perfetto brown marble | Calacatta gold marble | Black and Gold marble     |                     |                        |              |                      |                      |
| <b>Code</b> | <b>OPP1</b>          | <b>OPP2</b>            | <b>OPP3</b>            | <b>OPP6</b>           | <b>OPP7</b>           | <b>OPP9</b>               |                     |                        |              |                      |                      |
| Marble      | ●                    | ●                      | ●                      | ●                     | ●                     | ●                         |                     |                        |              |                      |                      |





**graphic**

Matteo Paoloni

**concept and stylist creator**

Morena Colombo

**photo**

IKB Studio

**allestimenti**

Ottonove

**print**

Grafiche Boffi

**thanks to**

Edizioni Design

[www.edizionidesign.com](http://www.edizionidesign.com)

Martinelli Luce

*Book Village fashion bookstore*

Laminam S.p.A

*Lastre Ceramiche*

*Serie I Naturali, Onice*

*Dimensione 1000x3000 Spessore 5mm*

Vistosi Luce

Amini

Arco gallery

*Quadro più grande: Melania Acanfora, OPPOSTI*

*Quadro più piccolo: Melania Acanfora, SILENZIO*

De Vecchi Milano 1935

*Argenti*

Rosenthal

Colore 031

all rights reserved © 2016

**marelli**

**Giulio Marelli Italia SpA**

Via Indipendenza 159 20821 Meda (MB) ITALIA T +39 0362 342116

[info@giuliomarelli.com](mailto:info@giuliomarelli.com) [www.giuliomarelli.com](http://www.giuliomarelli.com)

# marelli

Giulio Marelli Italia SpA  
Via Indipendenza 159  
20821 Meda (MB) Italia  
T ++39 0362 342116  
info@giuliomarelli.com  
www.giuliomarelli.com

